



731A seismic accelerometer and
P31 power unit/amplifier
Operating guide

Caution: This manual should be read carefully before installation.



Contents

1.0 Introduction	3
2.0 Description	3
2.1 731A seismic accelerometer.....	3
2.2 P31 power unit/amplifier.....	3
2.2.1 P31 options.....	4
3.0 Operation	4
3.1 Inspection.....	4
3.2 Preparation for use.....	4
3.3 Measurement use.....	4
3.4 Precautions in use.....	5
3.5 Alternate power supply.....	5
4.0 Maintenance and troubleshooting	5
4.1 Battery replacement.....	6
4.2 Amplifier and accelerometer checks.....	6
5.0 Technical assistance	6
5.1 Technical assistance.....	6
5.2 Customer service.....	6



1.0 Introduction

The 731A seismic accelerometer and P31 Power Unit Amplifier are a unique state-of-the-art system for the measurement of extremely low level vibrations. This system has the capability to measure to the sub-micro g level by combining a high sensitivity piezoelectric sensing element, an integral ultra-low noise amplifier and a matching low-noise amplifier/filter/power supply. The amplifier also contains an integration circuit to yield an output proportional to velocity.



This system is particularly suited for the measurement of low level vibrations in bridge, building, tower and dam motion studies, optical and photographic stability monitoring, electron microscope and microtome monitoring, as well as vibration-isolation table monitoring.

2.0 Description

2.1 731A seismic accelerometer

The 731A seismic accelerometer incorporates an isolated piezoelectric sensing element which minimizes the effects of transverse motion, base strain, and thermal transients. The accelerometer also contains a proprietary solid state charge amplifier with an extremely low noise floor. This enables the sensing of low level vibration with a device which has a sensitivity of 10 V/g. The 731A accelerometer is relatively small and comes in a case for safe transport. Due to its extremely high sensitivity, the 731A is fragile. Do not drop it! Protect the unit at all times from accidental impacts. Handling vibration and shock must not exceed 15 g peak.

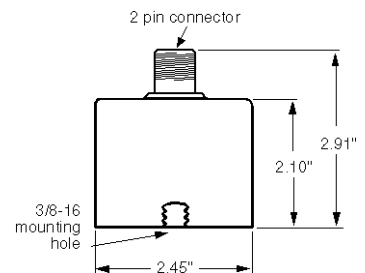

2.2 P31 power unit/amplifier

The P31 power unit/amplifier is specifically designed to further enhance the capabilities of the 731A seismic accelerometer by providing signal amplification, selective filtering, and signal processing to yield user-selectable acceleration or velocity output signals. It also provides the constant current needed to power the accelerometer's internal amplifier.

The P31 is battery powered, using two standard 9 volt alkaline transistor batteries with an operating life of approximately 75 hours. The green LED lamp glows for good battery condition when the power switch is moved to the TEST position. All switches and the indicator light are on the front panel, input and output connectors are on the rear panel. The power unit provides 2.4 mA constant current to the 731A accelerometer. A selectable-gain amplifier provides gains of 1, 10, and 100.

Acceleration or velocity output is switch selectable. The two acceleration settings provide integral filtering with nominal system band-widths (minus 3 dB) of 0.05 to 450 Hz, and 0.05 to 100 Hz, respectively. The velocity setting yields a nominal system response of 1.5 to 150 Hz (± 1 dB),



with outputs of 0.1 V/in/sec, 1 V/in/sec, and 10 V/in/sec for the three gain levels of 1, 10, and 100.

2.2.1 P31 options

The P31-1 has a slightly different design than that of the P31. The filter and velocity switch that is present on the P31 is disabled on the P31-1. By removing all filters, the phase change from input to output is minimized. However, the resonance of the accelerometer is not dampened, so the user should take care not to overload the system at the natural frequency.

3.0 Operation

3.1 Inspection

After carefully unpacking the 731A seismic accelerometer, the P31 power unit/amplifier, and cables, inspect the external parts for damage to switches, indicator and connectors. If there is damage, file a claim with the carrier who transported the instrument. Retain the shipping container and packing material for use in case reshipment is required.

Caution: Use great care in handling the 731A. It is fragile. Never DROP it or hit it against a solid object.

3.2 Preparation for use

Mount the 731A on the test structure using a 3/8-16 UNC stud. The mounting surface should be about 2 3/4" (70 mm) in diameter, flat and clean. Hand-tighten the accelerometer; do not use a wrench. Alternatively, the accelerometer may be fastened using cement or bee's wax. Care must be taken that the accelerometer is not accidentally dislodged and damaged. Particular care is needed when mounting the accelerometer to the side of structure (sensitive axis horizontal). A threaded stud is recommended in this case.

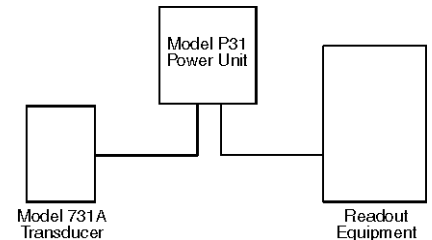

Depress POWER SWITCH of the P31 Power Unit/Amplifier to TEST position. BATTERY CONDITION INDICATOR should show a steady green light, release switch. Connect the cable to the input connector on the P31 and to the 731A seismic accelerometer. This cable should be free of kinks and cable connectors should be clean. Connect one end of a coaxial cable to the output BNC connector on the rear panel of the P31 and connect the other end of the cable to the readout or recording instrument.

Caution: The input connector of the P31 is a twin-axial BNC. Attempting to insert a co-axial BNC can cause damage to the input connector.



3.3 Measurement use

Set FILTER SWITCH to desired mode of operation: “Acceleration, 450 Hz low pass”, or “Acceleration, 100 Hz low pass”, depending on desired frequency range of measurement. If an output proportional to velocity is desired, set filter switch to “VELOCITY”.

Set GAIN SWITCH to desired gain setting. Good operating practice starts with the lowest gain setting to prevent amplifier overloading if input signals are larger than anticipated. Gain settings of 1, 10, and 100 result in system sensitivities (with the 731A seismic accelerometer) of 10, 100, and 1000 V/g, respectively, for both acceleration functions, and 0.1, 1, and 10 V/in/sec for the velocity function.

Note: It takes about 2 minutes after power-on before the system is ready for use.

3.4 Precautions in use

The 731A seismic accelerometer is fragile and must be handled gently. The P31 should not be subjected to environments in excess of its specified temperature and humidity ranges. It should be protected from condensation and corrosive atmospheres.

3.5 Alternate power supply

The P31 was specifically designed to optimize the capabilities of the 731A seismic accelerometer. The accelerometer can, however, be operated with an alternate power supply, consisting of a constant current diode rated at 2 to 10 mA (J5XX series, Siliconix, InterFET, etc.) fed from a +18 to +30 VDC constant voltage supply. A DC voltage will be present at the output of the accelerometer. A blocking capacitor and shunt resistor (as shown in the figure below) may be added to decouple the DC voltage. The time constant of the capacitor-resistor combination must be large enough not to degrade the capability of the 731A accelerometer (-3 dB at 0.05 Hz). For example, using a 100 mF capacitor and 500 K resistor results in a time constant of 50 seconds (.02 Hz).

The 731A has a two pin (MIL-C-5015) connector with pin A for the DC constant current input and signal high (signal output), and pin B for the signal return.

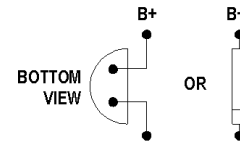
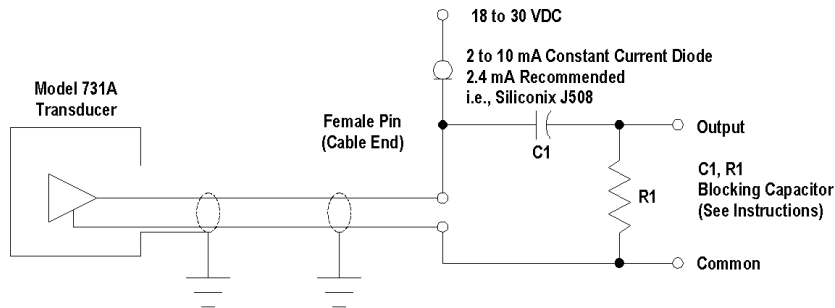

CONSTANT CURRENT DIODE CONNECTION
 Caution: The constant current diode must be properly installed to protect the internal amplifier from damage.

4.0 Maintenance and troubleshooting

The P31 power unit/amplifier is fully calibrated and ready to operate when received from Wilcoxon Sensing Technologies. A new set of 9 volt alkaline batteries is mounted in the power unit. Under normal circumstances, those batteries have an operational life of about 75 hours.

4.1 Battery replacement

The batteries need to be replaced when indicated by the absence of the green light from the battery condition indicator. Turn the P31 upside down, remove the retaining screws in the bottom panel and slide the chassis out from the cover box. The batteries are located in an internal holder. Simply remove the batteries from the holder and plug in the new batteries. Slide the chassis back into the cover box and replace the 4 retaining screws. Set the "POWER" switch to the "TEST" position. The green LED should illuminate. If it fails to illuminate, repeat the procedure. Call customer service if the LED continues to fail to illuminate.

4.2 Amplifier and accelerometer checks

If the P31 power unit/amplifier appears to malfunction, its operation can be checked electrically. The output of a signal generator (at about 30 Hz) is fed through an RC network into the input of the P31 power unit/amplifier. This network consists of a 100 μ F capacitor in series with the input and a 3.74 k Ω resistor shunted across the input. In this electrical signal substitution method the signal generator is set to produce an output signal with an amplitude of about 3 V rms at each gain setting. (Example: At a switch setting of "ACC 1000" a 30 mV signal output will produce a 3 volt RMS signal out.) If this test indicates P31 malfunction, the unit should be returned to the factory for repair.

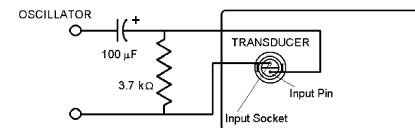

Note: If there is no signal output or the signal appears to be distorted or clipping, assure that you are not exceeding the maximum operating range of the unit, 0.5g. Excessive vibration or shock may cause the amplifier to go into an overload condition. After the 731A amplifier has overloaded due to excessive vibration or shock, there will be no signal output until the amplifier recovers. The recovery time of the amplifier can be 2 to 3 minutes after the overload condition is removed.



If the 731A appears to malfunction, one should measure the DC level (bias output voltage) at the output of the accelerometer (e.g. input of the P31) using a portable vibration monitor. Note that the turn on time is about two minutes. With no significant vibration input, the DC level should be about +9 VDC. Much lower or higher (>11V or <7V) DC voltages indicate internal problems. If tests indicate either the P31 or the 731A is not functioning correctly, contact customer service for assistance. See section 5.0 of this manual.

5.0 Technical assistance

5.1 Technical assistance

For technical assistance, please contact Wilcoxon Sensing Technologies at 301-330-8811, fax 301-330-8873, or email info@wilcoxon.com.

5.2 Customer service

To obtain a return goods authorization number, please contact customer service at 301-330-8811, or email info@wilcoxon.com.