



Meggitt Sensing Systems

Application solution

Mounting 4-20 mA vibration sensors on fans



Continuous monitoring

This article provides guidance to determine the number and location of 4-20 mA loop powered sensors (LPS™) which produce a reliable vibration monitoring system to protect fans. LPS™ interface directly with a plant Programmable Logic Controller or Distributed Control System to provide a cost-effective predictive maintenance solution.

Measurement directions

Fan monitoring typically utilizes triaxial measurements taken in the vertical (V), horizontal (H), and axial (A) directions. The vertical and horizontal measurements are meant to be perpendicular to the rotating shaft. Axial is meant to be taken in the same direction as the shaft.

When mounting piezoelectric-based vibration sensors, the base of the sensor is mounted toward the shaft or bearing. Horizontal mounting can be done on either side of the bearing. Vertically mounted sensors can either be above or below the shaft; however it is normally more convenient to mount them on the top of the bearing.

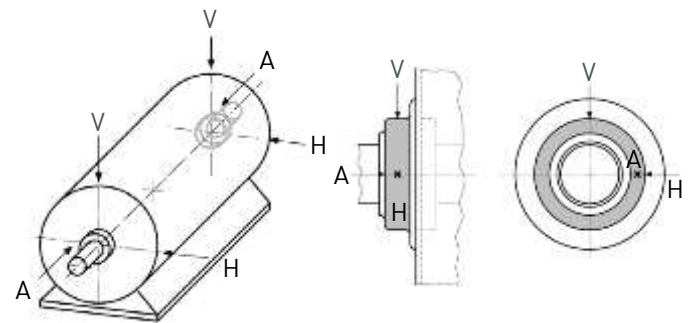

On belt-driven equipment the vertical and horizontal are sometimes rotated slightly so as to align the measurement with the direction of the shafts centerlines. In this case the horizontal is perpendicular to the shaft, but aligned to the opposite shaft.

Measurement locations

Machinery vibration analysts have developed some standard reference terminology for equipment locations. Monitoring points are usually designated as inboard (IB) or outboard (OB). Outboard is the side of the fan or motor away from the coupling or belt sheave. Inboard is the end of the fan shaft closest to the coupling or belt sheave. Further point identification is used to determine whether the point is on the fan (F) or motor (M), for example inboard fan (IBF) or outboard motor (OBM).

Belt driven equipment has a slightly different orientation when considering the "horizontal" direction. The horizontal direction for the shaft ends with the belt sheaves is directed between the shafts. In other words, the horizontal for one shaft is "pointed" at the other shaft.

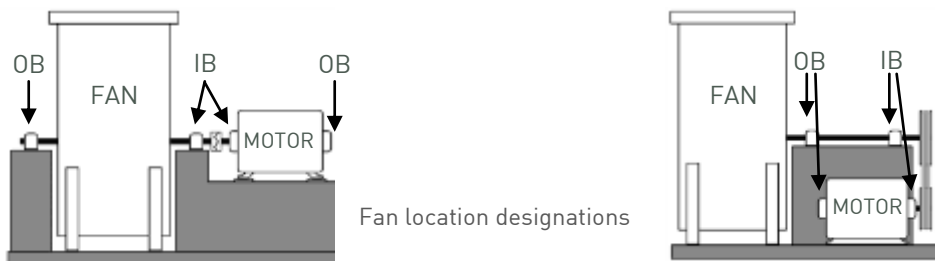



Measurement preferences

When viewed as a whole system, a fan has a maximum number of twelve measurement positions. Each of four typical locations has a possible three measurement axes (vertical, horizontal, and axial).

Vibration measurements made using a portable data collector (analyzer) usually will be taken at all twelve positions. Because the data is acquired at intervals of a month or more, it is relatively simple to just take data from all positions while the vibration technician is at the fan, providing the maximum amount of data for analysis in the minimum amount of time.

When it comes to mounting accelerometers for predictive maintenance programs a question often asked is, "Do I really need to install accelerometers in all three axes at each bearing location?" The answer is "No". Even ISO 10816 which sets the industry standard for vibration monitoring allows that only one or two measurements at a bearing position are necessary for operational needs.

When sensors are mounted permanently on a fan and connected to a continuous vibration monitoring system, such as a PLC or DCS, all twelve possible measurement positions do not have to be monitored. When the data interval is many weeks apart it makes sense to acquire all possible measurements. If the data interval is only a few seconds as with a continuous vibration monitoring system, PLC, or a DCS, then fewer positions are required to be monitored.

Data that is acquired at the same point hundreds or thousands of times per day affords the observer the luxury of a continuous data stream for trending vibration events. With such frequent data the observer can easily spot developing trends in the vibration data. If the data is combined with other information in the PLC or DCS then the observer is able to correlate the vibration information with plant operating conditions. This can help to interpret any changes in vibration making the vibration data all the more useful.

Axial measurements

If measurements are being taken at each bearing position, are axial measurements at all necessary? While not absolutely necessary, at least one axial measurement should be taken at the bearing position where there is a thrust bearing or a bearing that can act to accept an axial load. Some vibration problems will exhibit symptoms better in the axial direction than in the radial direction. This vibration energy can be measured best at the bearing location where axial loading will transmit to the bearing case.

Some additional guidance as to monitoring locations will come from the actual maintenance history of the machine. If the fan, or similar types has a history of some particular fault mode, that fault mode should be used for guidance as to where to mount vibration sensors. For example, if a particular model of fan usually has problems with imbalance, it would be a good idea to monitor a bearing of the fan in the radial direction. If a user were to only have the ability to mount one permanent sensor, the user should tend toward mounting that one sensor in a location most likely to indicate the historical failure mode of the fan.

Two of the greatest problems facing the vibration analyst are how many sensors to mount and where to place them. For typical equipment sets of direct-driven fans there will usually be four total bearings with one of them acting as a thrust bearing. This means a total of five sensors would be the usual optimum number of sensors because there will be one radial measurement, usually horizontal, at each bearing and one axial measurement at the bearing that acts as a thrust bearing by being able to accept an axial load.

However, no matter what guidance the vibration analyst uses for placement of permanent sensors, the best guidance is to use common sense and good judgment.

Wilcoxon LPS series sensors

Meggitt's extensive line of 4-20 mA loop powered sensors meets the needs of virtually every application. LPS™ are ordered with a selectable full scale in terms of acceleration or velocity, output in terms of RMS, equivalent peak, or true peak, and dual output of dynamic data is also available in acceleration or velocity. Standard products include environmental protections such as side exit connectors, integral cables, intrinsically safe sensors, and explosion proof housing.



Typical recommended sensor locations

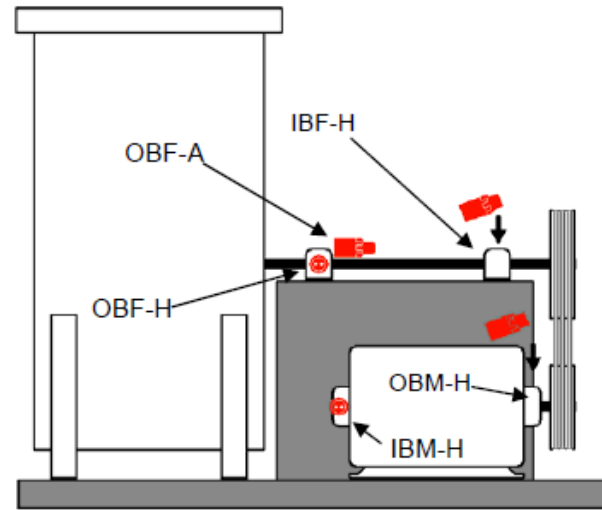

Belt driven fan side

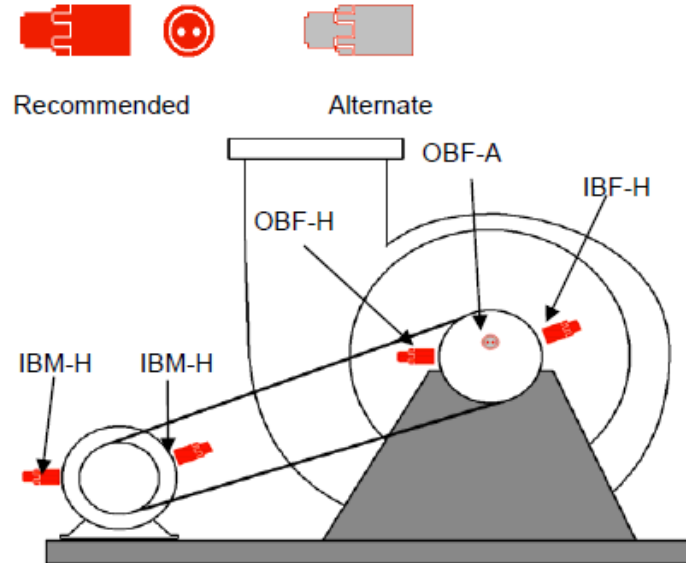

Belt driven fan end shaft

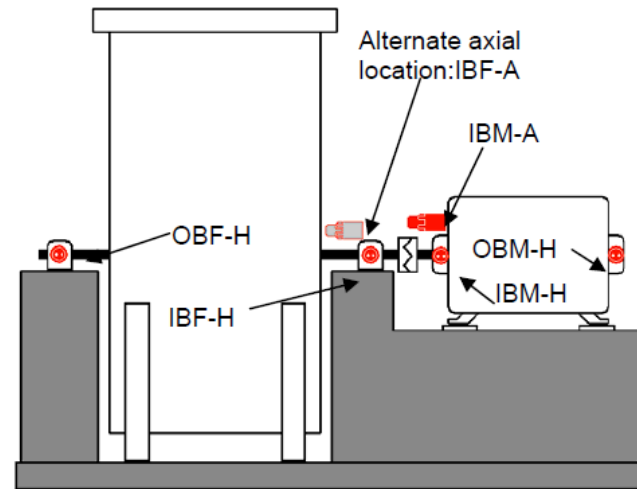

Direct drive simply supported

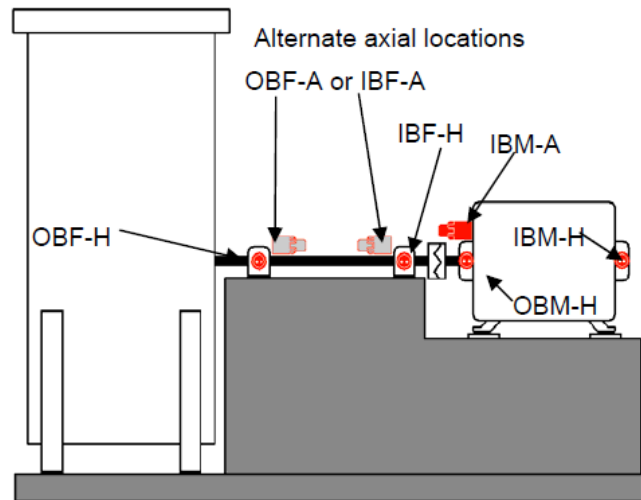

Direct drive overhung