



Electromagnetic shakers operating guide Models F3, F4, F5B, F10

Caution: This manual should be read carefully before installation



WARNING: OPERATION OF THE ELECTROMAGNETIC SHAKER IS SAFE WHEN THE INSTRUCTIONS IN THIS MANUAL ARE READ THOROUGHLY. PARTICULAR ATTENTION MUST BE PAID TO THE SAFETY SECTION OF THIS MANUAL.

WARNING: TO PREVENT FIRE OR SHOCK HAZARD, DO NOT EXPOSE THIS EQUIPMENT TO RAIN OR MOISTURE.

WARNING: LETHAL VOLTAGES ARE PRESENT IN THE AMPLIFIER AND MATCHING NETWORKS.

Safety section

The electromagnetic shakers can be safely operated when the instructions in this manual are carefully followed.

This section summarizes the safety considerations. Reminders, in the form described below, will appear in the detailed instructions to assure operator awareness of these safety considerations. Qualified personnel should operate and maintain this power amplifier only after becoming thoroughly familiar with this manual.



WARNING: This symbol is used in the instruction manual where operator safety must be considered. The instruction manual should be consulted and read carefully.



CAUTION: This symbol is used when caution is needed to prevent damage to equipment. It is used where careful attention to certain procedures described in the instruction manual is needed. This symbol is also used to emphasize procedures other than normal operating procedures.



Safety summary

1. Make sure that the power amplifier is properly grounded to a good earth ground.
2. Make sure that any piezoelectric shaker being driven is properly grounded to a good earth ground.
3. Disconnect the power cord at its source before connecting or removing any cables.
4. To reduce the risk of electric shock, do not remove the power amplifier cover. No user-serviceable parts are inside. Refer all servicing issues to Wilcoxon Sensing Technologies.
5. Do not attempt to operate a power amplifier without the protective covers secured.
6. All cables must be connected between the power amplifier, matching network and shaker before electrical power is connected. Inspect for frayed or cut cables prior to operation.
7. Wear hearing protection when driving piezoelectric shakers at high levels and high frequencies.
8. Do not expose this equipment to rain or moisture.
9. Lethal High voltage may be present at any of the equipment connectors.
10. The Wilcoxon Sensing Technologies Model D125L piezoelectric shaker requires pressurization (minimum 1800 PSI) from a source of dry, inert gas. The shaker must be electrically connected to the matching network and power amplifier, or the shaker terminals should be shorted together, prior to pressurization or de-pressurization. Pressure must be applied or released slowly (1 minute) to prevent excessive voltages at the shaker connecting terminals. Use extreme caution when handling pressurized cylinders.
11. Use common sense and avoid haste!



Contents

Safety section	2
Safety summary	3
1.0 Theory of operation	5
1.1 Model F3 electrodynamic shaker.....	6
1.2 Model F4 electrodynamic shaker.....	6
1.3 Model F5B electrodynamic shaker.....	7
1.4 Model F10 electrodynamic shaker.....	7
2.0 Initial system setup	8
2.1 Checking components.....	8
2.1.1 Model F3 electrodynamic shaker.....	8
2.1.2 Model F4 electrodynamic shaker.....	9
2.1.3 Model F5B electrodynamic shaker.....	9
2.1.4 Model F10 electrodynamic shaker.....	9
2.2 Mounting instructions.....	9
2.2.1 Model F3 electrodynamic shaker.....	10
2.2.2 Model F4 electrodynamic shaker.....	10
2.2.3 Model F5B/Z11 electrodynamic shaker.....	11
2.2.4 Model F10 electrodynamic shaker.....	12
2.3 Connect the power amplifier.....	12
2.4 Connect the matching network.....	12
2.5 Electrical connection instructions.....	13
2.6 Air cooling connections.....	13
2.7 Model Z7 impedance head connection.....	14
3.0 Operation	14
4.0 Maintenance	15
4.1 Troubleshooting electromagnetic shakers.....	15
5.0 Technical assistance	16
5.1 Technical assistance.....	16
5.2 Customer service.....	16



1.0 Theory of operation

Electromagnetic shakers operate on the principle of magnetism. Electric current in a wire will establish a magnetic field. When the wire is wound in a coil the effect of the magnetic field is multiplied because of the multiple windings of the coil. The change of current flow in the coil will produce a varying magnetic field.

Figure 1 illustrates a suspended coil with a permanent magnet surrounding the windings. This results in a system that can generate electric currents when the coil is moved within the magnetic field of the permanent magnet. Conversely, if the permanent magnet is held still and alternating electric currents are allowed to flow in the coil, then the suspended coil will develop vibratory motion. This is the principle of the electromagnetic shaker.

This is also the same principle used in audio speakers. The difference being the output of the speaker coil, commonly called the voice coil, is acoustic energy.

The speaker's acoustical energy is generated because of the motion of the cone of the speaker being moved by the connected voice coil. An electromagnetic shaker uses the same principle, but instead, uses the vibratory motion to "shake" a structure – hence the term shaker.

A reaction shaker is a shaker where the coil is mounted to a structure or item under test. The rest of the shaker mass becomes the mass against which the forces generated by the shaker coil react – hence the term reaction shaker. In effect, the mass of the shaker body is used to shake the structure.

Wilcoxon's electromagnetic shakers are all designed to be reaction mass shakers. They are generally used for laboratory excitation of structures for testing.

1.1 Model F3 electromagnetic shaker

The Model F3 electromagnetic shaker is a cylindrical, permanent magnet, reaction-type shaker that generates dynamic forces for structural excitation in vibration research and testing. The reaction principle of operation, combined with a lightweight and compact configuration, allows this generator to be stud mounted in any position directly to structures without external support or critical shaft alignment problems. Its light coil and bobbin are rigidly attached to the test specimen by means of a mounting plug or Z602WA impedance head. The dummy plug is necessary to mount the shaker to a structure when the Z602WA impedance head is not used with this shaker.

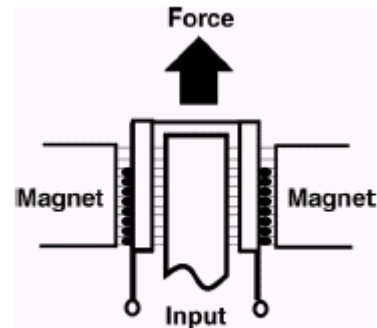

Figure 1 –
Electromagnetic shaker



Model F3/Z602WA
Electromagnetic shaker



Two rubber diaphragms on either end of the bobbin suspend the heavier magnets. The dynamic weight added to the system is relatively low since the rubber-suspended weight does not affect the axial or rotational inertia of the system above the resonant frequency of the suspension system. This prevents inconsistent results and difficulties encountered with other shakers whenever the rotational impedance of structures is low compared to the axial impedance.

1.2 Model F4 electromagnetic shaker

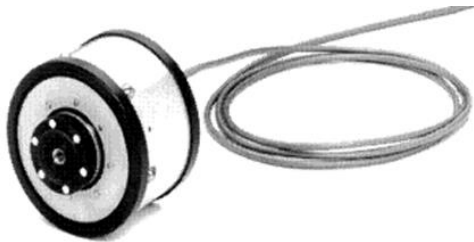

Model F4/Z820WA
Electromagnetic shaker

The Model F4 electromagnetic shaker is a compact, ring-shaped permanent magnet shaker. Its light coil and bobbin are rigidly attached to the dummy plug or Z820WA impedance head, which the shaker encircles. The dummy plug is necessary to mount the shaker to a structure when the Z820WA impedance head is not used with this shaker.

Two rubber diaphragms suspend the heavier magnets, one near the top and the other near the base of the transducer just above the force gauge.

The dynamic weight added to the system is relatively low since the rubber suspended weight does not affect the axial or rotational inertia of the system above the resonant frequency of the suspension system. This prevents inconsistencies in results and difficulties encountered with other shakers whenever the rotational impedance of structures is low compared to the axial impedance.

This shaker also has provisions for air cooling, thereby permitting operation at higher currents for extended periods.

1.2.1 Model F4/F7 electromagnetic/piezoelectric shaker system

The Wilcoxon Model F4/F7 electromagnetic/piezoelectric shaker system combines the advantages of the low frequency F4 electromagnetic shaker with the high frequency characteristics of the F7 piezoelectric shaker. The F4 encircles the F7 to form a compact, lightweight shaker system capable of producing a high force-to-weight output over a very wide frequency range. Each shaker requires its own power amplifier and the F7 piezoelectric shaker also requires a matching network. The operating guide for piezoelectric shakers contains information about the operation of the F7 piezoelectric shaker.

When the F4 electromagnetic shaker is combined with the F7 piezoelectric shaker into the F4/F7 electromagnetic/piezoelectric shaker system, the two generators may operate independently for maximum force



Model F4/F7-1
Electromagnetic/piezoelectric shaker



output in smaller bands, or in tandem. When used in tandem, the entire frequency range can be swept without circuit switching.

1.3 Model F5B electromagnetic shaker

The Model F5B vibration generator is a reaction-type shaker generating dynamic forces for structural excitation in vibration research and testing. The reaction principle of operation



Model F5B/Z11
Electromagnetic shaker

combined with a lightweight and compact configuration allows this generator to be stud mounted in any position directly to structures without external support or critical shaft alignment problems. The F5B may be driven at a maximum continuous current of 0.2 Arms from 150 Hz to 10 kHz, and 0.1 Arms from 70 Hz to 150 Hz. A power amplifier or signal generator with a "clean" current output of at least 0.1 Ampere over the frequency range is needed to drive the F5B. The use of an ammeter to monitor the oscillator output or the power amplifier output is recommended as currents in excess of the rated currents can permanently damage the F5B shaker.

1.4 Model F10 electromagnetic shaker

The F10 electromagnetic shaker is a ring-shaped permanent magnet shaker. Its light coil and bobbin are rigidly attached to the dummy plug or Z820WA impedance head, which the shaker encircles. Two rubber diaphragms suspend the heavier magnets, one near the top and the other near the base of the transducer base just above the force gauge. The dynamic weight added to the system is relatively low since the rubber-suspended weight does not affect the axial or rotational inertia of the system above the resonant frequency of the suspension system. This prevents the inconsistencies in results and the difficulties encountered with other shakers whenever the rotational impedance of structures is low compared to the axial impedance.



Model F10/Z820WA
Electromagnetic shaker

The F10 has a thermal breaker which will open and stop operation of the shaker if internal temperatures are exceeded. If this should occur, turn down the amplitude of the signal source and/or power amplifier. Wait for the shaker to cool down and then resume operation. This shaker also has provisions for air cooling, thereby permitting operation at currents above the normal rating for extended periods.



1.4.1 Model F10/F7 electromagnetic/piezoelectric shaker system

The Wilcoxon Model F10/F7 electromagnetic/piezoelectric shaker system combines the advantages of the low frequency F10 electromagnetic shaker with the high frequency characteristics of the F7 piezoelectric shaker. The F10 encircles the F7 to form a compact, lightweight shaker system capable of producing a high force-to-weight output over a very wide frequency range. Each shaker requires its own power amplifier and the F7 piezoelectric shaker also requires a matching network. The operating guide for piezoelectric shakers contains information about the operation of the F7 piezoelectric shaker.

When the F10 electromagnetic shaker is combined with the F7 piezoelectric shaker into the F10/F7 electromagnetic/piezoelectric shaker system, the two generators may operate independently for maximum force output in smaller bands, or in tandem. When used in tandem, the entire frequency range can be swept without circuit switching.

2.0 Initial system setup

While the electromagnetic shaker, itself, does not have any operating controls or settings, it functions as a part of a total system for vibration excitation. This system should be checked using the procedures outlined in this section for complete installation.



CAUTION: Complete all of these steps before operating the shaker system.

2.1 Checking components

After carefully unpacking the products and accessories, inspect all external parts for visible damage to cabinets, switches, indicators, and connectors. If there is damage, file a claim with the carrier who transported the system. Retain the shipping containers and packing material for use in case reshipment is required.



CAUTION: Do not drop the shaker. The outer cylinder of the electromagnetic shaker is made of relatively thin material and any deformation may jam the coil. If space permits, it is recommended that a thick piece of protective material, such as foam rubber, be wrapped around the periphery to prevent accidents.

Ensure that you have all components of the purchased system.

2.1.1 Model F3 electromagnetic shaker

The F3 electromagnetic shaker is supplied with an R1-22-J93-10-P1 input cable for connection to a Wilcoxon power amplifier. The Z602WA impedance head or the F3 dummy plug would also normally be ordered with the F3 electromagnetic shaker and will include a wrench and mounting stud. The Z602WA impedance head will be supplied with two (2) R1-2-J93-





10 connection cables. These are 10-32 coaxial Microdot™-to-BNC cables for the force and acceleration transducers built into the Z602WA impedance head.¹

2.1.2 Model F4 electromagnetic shaker

The F4 electromagnetic shaker is supplied with an R4M-22-J9B-10 input cable for connection to a Wilcoxon power amplifier. The Z820WA impedance head or the F4 dummy plug would also normally be ordered with the F4 electromagnetic shaker that will include a wrench and mounting stud. The Z820WA impedance head will be supplied with two (2) R2-2-J5-10 connection cables. These are BNC-to-BNC cables for the force and acceleration transducers built into the Z820WA impedance head.¹



2.1.3 Model F5B electromagnetic shaker

The F5B electromagnetic shaker is supplied without an input cable. The input connector for the F5B electromagnetic shaker is a BNC type connector. If the Z11 impedance head is ordered with the F5B it will be supplied with two (2) R1-3A-J2-6 cables. These are Wilcoxon type 3A (5-44)-to-Microdot™ (10-32 coaxial) cables for the force and acceleration transducers built into the Z11 impedance head.²



2.1.4 Model F10 electromagnetic shaker

The F10 electromagnetic shaker is supplied with an R4M-22-J9B-10 input cable for connection to a Wilcoxon power amplifier. The Z820WA impedance head or the F10 dummy plug would also normally be ordered with the F10 electromagnetic shaker and will include a wrench and mounting stud. The Z820WA impedance head will be supplied with two (2) R2-2-J5-10 connection cables. These are BNC-to-BNC cables for the force and acceleration transducers built into the Z820WA impedance head.

2.2 Mounting instructions

The mounting surface of the sensing transducer (Wilcoxon impedance head), dummy plug, or F7 piezoelectric shaker must rest flush against the test structure. Do not dent the shaker mounting surface when mounting to test structure. A thin coating of grease should be applied to the contact boss. This will assist mechanical coupling at high frequencies.

The Models F3, F4, and F10 of electromagnetic shakers can be supplied with either a Wilcoxon impedance head or a dummy plug. The dummy plug is an aluminum body with the same dimensions and mounting configuration as the impedance head.

Notes:

1. Force and acceleration transducers require external IEPE power supplies and/or signal conditioning units. Contact Wilcoxon for more information.
2. In addition to IEPE and signal conditioning requirements, Z11 impedance heads require Model CC701 charge converters. Contact Wilcoxon for more information.



2.2.1 Model F3 electromagnetic shaker

The F3 electromagnetic shaker system is attached to the structure by means of a 10-32 UNF threaded stud located on the end of the Z602WA impedance head or dummy plug F3, #35047. The 0.56 inch boss should rest tight and flush against the structure.

The contacting surface of the test structure and contacting boss of the mounting base must be inspected for grit or burrs prior to attachment to insure accuracy of transducer sensitivity. A thin coating of grease should be applied to the contact boss to improve mechanical coupling at high frequencies. When attaching the mounting base (impedance head) to a structure, tightening should only be done by a spanner wrench in the holes provided in the base. No torque should ever be applied to the body of the F3 electromagnetic shaker itself.

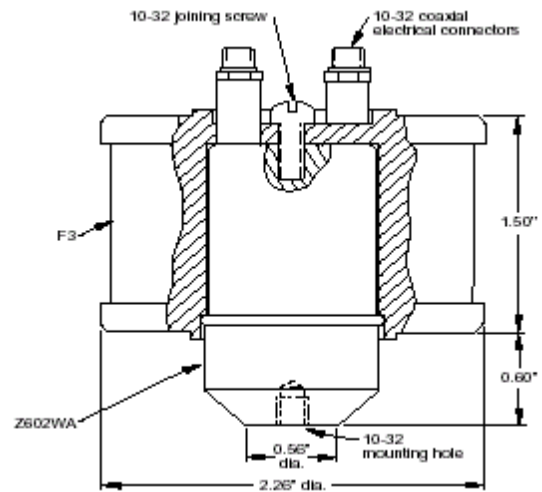

2.2.2 Model F4 electromagnetic shaker

The F4 electromagnetic shaker can be mounted on the test structure in three different ways. In all cases, the attachment is by means of a threaded 3/8-16 UNC stud in the mounting surface boss of the plug or impedance head. The boss should rest tight and flush against the structure. The contacting surface of the test structure and contacting boss of the mounting base must be inspected for grit or burrs prior to attachment to insure accuracy of transducer sensitivity.

A thin coating of grease should be applied to the contact boss to improve mechanical coupling at high frequencies. When attaching the mounting base (impedance head) to a structure, tightening should only be done by a spanner wrench in the holes provided in the base. No torque should ever be applied to the body of the F4 electromagnetic shaker itself.

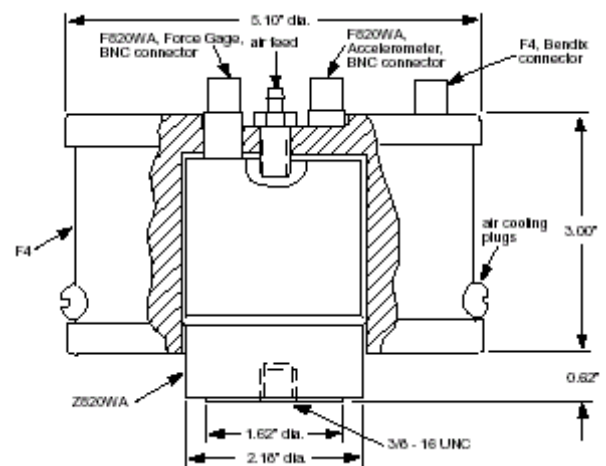

- 2.2.2.1 The F4 electromagnetic shaker can be mounted by means of the Z820WA impedance head with one end attached to the F4 electromagnetic shaker and its other end to the test structure.



2.2.2.2 A simple aluminum cylinder (dummy plug F4, #35227) of the same dimension as the Z820WA impedance head can be used with one end attached to the F4 electromagnetic shaker and its other end to the test structure.

2.2.2.3 If using the F4 electromagnetic shaker in conjunction with the F7 piezoelectric shaker, the F7 (located within the F4) serves as the attachment means of the F4/F7 combination.

2.2.3 Model F5B/Z11 electromagnetic shaker

The F5B is attached to the structure or Z11 impedance head by means of the integral 8-32 UNC threaded hole in the face of the F5B. The shaker has a ½ inch diameter boss in contact with the impedance head or the mounting surface if no impedance head is used. The Z11 impedance head contains a piezoelectric accelerometer and a piezoelectric force gauge. These are high impedance, charge-mode sensors and require a Wilcoxon charge converter and IEPE power supply. The output is from two coaxial (leprechaun™) connector jacks on the periphery of the transducer. They are marked “A” for acceleration and “F” for force, and require 3A leprechaun™ cables.

An 8-32 UNC by 0.175 inch stud with 8-32 thread is located on each end of the Z11 impedance head. The Z11 impedance head has a ¼ inch boss at each end of the impedance head. The boss should rest tight and flush against the test structure and the F5B electromagnetic shaker.

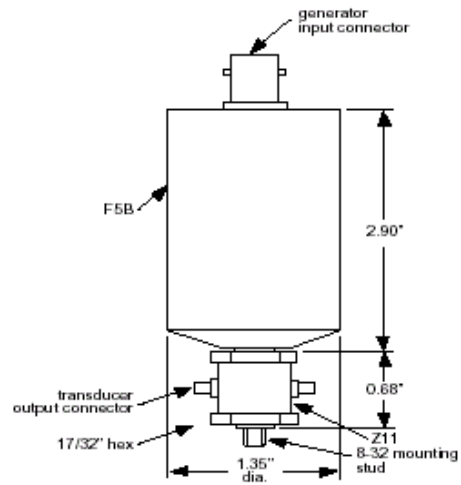

The contacting surface of the test structure and contacting boss of the mounting base must be inspected for grit or burrs prior to attachment to insure accuracy of transducer sensitivity. A thin coating of grease should be applied to the contact boss to improve mechanical coupling at high frequencies. When attaching the mounting base (impedance head) to a structure, tightening should only be done by a wrench on the hexagonal ends of the impedance head. The F5B electromagnetic shaker should be hand-tightened to the Z11.



2.2.4 Model F10 electromagnetic shaker

The F10 electromagnetic shaker can be mounted on the test structure in three different ways. In all cases, the attachment is by means of a threaded 3/8-16 UNC stud in the mounting surface boss of the plug or impedance head. The boss should rest tight and flush against the structure. The contacting surface of the test structure and contacting boss of the mounting base must be inspected for grit or burrs prior to attachment to insure accuracy of transducer sensitivity. A thin coating of grease should be applied to the contact boss to improve mechanical coupling at high frequencies. When attaching the mounting base (impedance head) to a structure, tightening should only be done by a spanner wrench in the holes provided in the base. No torque should ever be applied to the body of the F10 electromagnetic shaker itself.

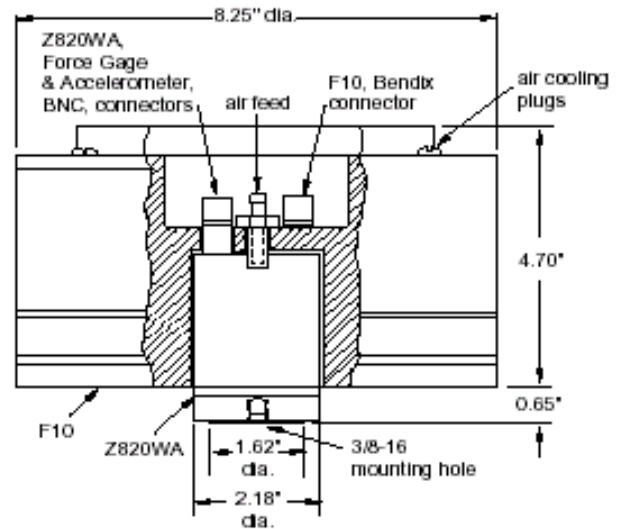

- 2.2.4.1 The F10 electromagnetic shaker can be mounted by means of the Z820WA impedance head with one end attached to the F10 electromagnetic shaker and its other end to the test structure.
- 2.2.4.2 A simple aluminum cylinder (dummy plug F4, #35227) of the same dimension as the Z820WA impedance head can be used with one end attached to the F10 electromagnetic shaker and its other end to the test structure.
- 2.2.4.3 If using the F10 electromagnetic shaker in conjunction with the F7 piezoelectric shaker, the F7 (located within the F10) serves as the attachment means of the F10/F7 combination.

2.3 Connect the power amplifier

Wilcoxon power amplifiers are purchased and shipped separately from vibration shaker system products. Refer to the operating guide supplied with the power amplifier for connection and operating instructions. If using a power amplifier other than one supplied by Wilcoxon Sensing Technologies, follow that manufacturer's recommended procedure for installation and operation.

2.4 Connect the matching network (using an F7 piezoelectric shaker)

Wilcoxon Sensing Technologies matching networks are purchased and shipped separately from vibration shaker system products. Refer to the operating guide supplied with the matching network for connection and operating instructions. Refer to the operating guide supplied with the piezoelectric shaker for connection and operating instructions.



2.5 Electrical connection instructions

1. Make sure that the AC line receptacle used for the power amplifier is properly grounded to a good earth ground.



WARNING: Do not operate the system without proper grounding.

2. If using an F7 piezoelectric shaker, decrease power to minimum before changing the matching network switch positions.

3. Before making any changes in electrical connections, turn the input signal off and turn the main power switch of the power amplifier off.

4. After the shaker system and its components are properly connected and mounted to the test specimen, the accelerometer and force gauge outputs in the impedance head should be connected to the proper signal conditioners and to the readout device. Note that the Z11 impedance head of the F5B also requires charge converters for the force and accelerometer transducer outputs.

5. The following table indicates the cable types and connections for Wilcoxon Research power amplifiers and electromagnetic shakers. This table should be consulted for guidance as to cable and equipment connection.

Table 2.5 – Interconnecting cables

Shaker model	Input interconnect cable
F3	R1-22-J93-10-P1
F4	R4M-22-J9B-10
F5B*	R2-22-J9C-10-P1
F10	R4M-22-J9B-10

* The F5B electromagnetic shaker can be driven directly from signal generators capable of producing 100 milliamperes of drive current.

2.6 Air cooling connections

If the F4 or F10 electromagnetic shaker will be operating at high force levels or for extended periods, air cooling should be provided to the shakers. A source of filtered, dry, oil free, air at a supply pressure of no more than 25 pounds per square inch (PSI). To cool by air, remove the 6 round head peripheral screws and connect an air hose to the fitting that is supplied. Without air-cooling the six round-head screws on the periphery of the shaker, which serve as air outlet holes, must always be in place to prevent any metal chips from entering the magnet assembly.



CAUTION: Electromagnetic shakers require protection from excessive current to prevent overheating.



Without air-cooling the continuous current to the F4 and F10 electromagnetic shakers should be limited. With air-cooling, the continuous current may be increased. Thus, the typical maximum force output can be increased. The F10 shaker incorporates a thermal circuit breaker that will open when excessive temperatures are developed within the F10 coil windings. The breaker will close when the temperature declines to an acceptable level for operation. The following is a table of the maximum allowable current for each of the shaker models.

Table 2.6 Maximum allowable current

Model	Maximum current RMS
F5B	0.1 Amp
F3	0.75 Amp
F4, no air cooling	1.5 Amp
F4, with air cooling	2.5 Amp
F10, no air cooling	2.5 Amp
F10, with air cooling	4 Amp

2.7 Model Z7 impedance head connection (Using the F7 piezoelectric shaker)

The Z7 impedance head is an integral part of the F7 piezoelectric shaker. It contains a piezoelectric accelerometer and a piezoelectric force gauge. The output from these high impedance, charge-mode sensors is from two 10-32 coaxial (Microdot) connector jacks on the periphery of the transducer. They are marked "A" for acceleration and "F" for force. Both require an IEPE power supply and/or signal conditioning plus Wilcoxon CC701-style charge converters.



3.0 Operation

The vibration generating system is ready for operation only after it has been thoroughly checked for proper electrical connections. The user should have selected a suitable location for the system, preferably in a sound isolated room, since the shaker may generate a considerable amount of sonic output. It is recommended that the operating personnel use hearing protection.

The following steps are suggested for operation of the vibration generating system:

1. Make sure the oscillator amplitude control is set with a minimum signal input to the power amplifier.
2. If using the F7 piezoelectric shaker and N7HF matching network, adjust the matching network selector switch to the lowest output amplitude setting.
3. (Optional, depending on your system configuration.) Turn on the vibration monitoring system consisting of the accelerometer and its associated output-measuring or display instruments.
4. Turn on the oscillator and set its frequency dial to the low end of the desired frequency range of the test sequence.
5. **STAND CLEAR OF THE SHAKER DURING OPERATION.**



6. Set the amplifier power switch to ON.
7. Slowly increase the signal generator amplitude control until the shaker generates the desired vibration level or until clipping of the power amplifier output occurs.
8. (Optional, depending on your system configuration) It is recommended to use a monitoring system to monitor the amplifier output to prevent overdriving the shaker.



CAUTION: Limiting the drive current to all electromagnetic shakers is strongly recommended.

9. Continue the test by changing the oscillator frequency dial and adjusting the amplitude control to attain the desired vibration levels.
11. Proceed as in steps 8 and 9 above.
12. When the test sequence is completed, reduce the signal generator amplitude to minimum then set the matching network's selector switch to the minimum output position.
13. Set the power amplifier power switch to OFF.

4.0 Maintenance

The electromagnetic shakers are virtually maintenance free. When AC voltage output from an appropriate amplifier is connected to the shaker, vibration energy should be generated. If no discernable vibration can be detected, even though voltages are input to the shaker, the shaker should be returned to Wilcoxon Sensing Technologies for evaluation.



CAUTION: The electromagnetic shaker contains no user-serviceable components. Service or repair of the shaker should not be attempted by anyone other than Wilcoxon Sensing Technologies employees or designated representatives.

4.1 Troubleshooting electromagnetic shakers

If the electromagnetic shaker does not appear to function, check the coil resistance using an ohmmeter. The following table may be used as a guide to the proper coil resistance for this check.

Table 4.1 Shaker nominal DC coil resistance

Model	Nominal coil resistance
F3	10 Ohms
F4	13 Ohms, pin A to pin B
F5B	56 Ohms
F10	5 Ohms, pin A to pin B

The insulation resistance of the coil to ground may also be checked. The insulation resistance for F4 & F10 shakers between both drive coil connections and ground should be at least 1 megOhm.



If damage is indicated, the shaker must be returned to Wilcoxon for repair.

Note: The F10 shaker contains a thermal overload switch. If the internal temperature exceeds the switch setting, the drive connection to the shaker coil will be interrupted. The switch will automatically reset when the internal temperature returns to an acceptable level.

5.0 Technical assistance

5.1 Technical assistance

For technical assistance, please contact Wilcoxon's Application Engineer at 301-330-8811, FAX to 301-330-8873, or email to info@wilcoxon.com.

5.2 Customer service

To obtain a return goods authorization (RGA) number, please contact customer service at 301-330-8811, fax to 301-330-8873, or email info@wilcoxon.com.