

Wiring guide for dual output vibration and temperature sensors

Wilcoxon Research manufactures three types of sensors that output a vibration signal and a DC voltage proportional to temperature.

The temperature signal is a DC voltage. It is not a thermocouple or a resistance-temperature device (RTD).

Type 1: The data-collector powered dual output sensor (Wilcoxon model 786T) is useful for acquiring data with any one of the many portable analyzers for collecting predictive data for vibration spectrum analysis. The temperature sensor is powered through the accelerometer powering circuit and provides the DC voltage output proportional to the temperature in degrees Celsius.

Type 2: The on-line system compatible dual output sensor (Wilcoxon models 793T-3 and 797T-1) requires the temperature sensor to be separately powered. Most on-line systems collect temperature separately from the vibration data. By allowing the system to power the temperature sensor separately, the scheduling of each reading (vibration or temperature) can be more readily accomplished.

Type 3: The 4-20 mA loop powered sensor style of dual output sensor (Wilcoxon LPS™ Series PC425 and PC427) output their temperature voltage directly to the 0-5 VDC or 1-5 VDC input of a distributed control system (DCS) or programmable logic controller (PLC).

The temperature sensor is separately powered and is not a 4-20 mA loop type signal. It is a DC voltage signal.

Model	Temperature output	General use
786T	10 mV/ °Celsius	Portable measurements
793T-3	10 mV/ °Kelvin	On-line systems
797T-1	10 mV/ °Kelvin	On-line systems
PC425	10 mV/ °Kelvin	Process systems
PC427	10 mV/ °Kelvin	Process systems

Meggitt Sensing Systems
 20511 Seneca Meadows Parkway
 Germantown
 MD 20876
 USA

Tel: +1 (301) 330 8811
 Fax: +1 (301) 330 8873

www.wilcoxon.com
www.meggitt.com

Portable data collector measurements using permanently installed dual output accelerometers

The 786T was specifically designed to work with most portable analyzers that allow the acquisition of both vibration and temperature data. Typically, the portable analyzer powers the accelerometer circuit and has a secondary input to measure the voltage developed from the temperature sensing portion. Many portable analyzers do not provide power to the temperature sensor, which is why the temperature sensor gets its power from the accelerometer powering circuit.

When wiring the shield, it only needs one termination point.

The 786T, when permanently installed for dual vibration and temperature measurements, should be wired to two channels of a vibration switch box. The three pin connections of the 786T are: A - Accelerometer power & signal, B - Signal common for acceleration and temperature, and C - Temperature signal.

If the switch board used for temperature has a BOV meter, it will indicate the DC voltage of the powered temperature sensor.

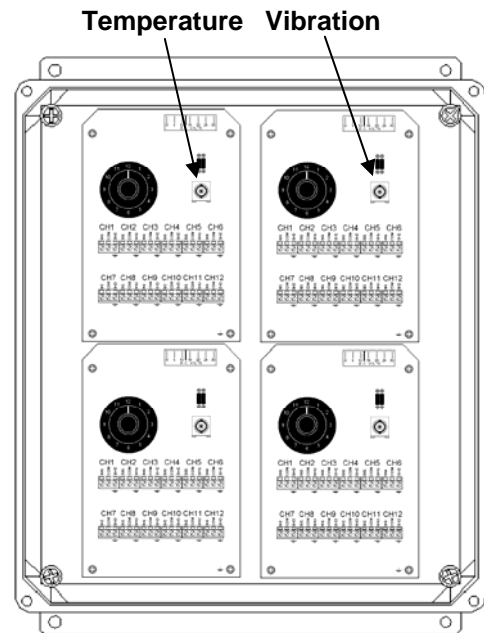
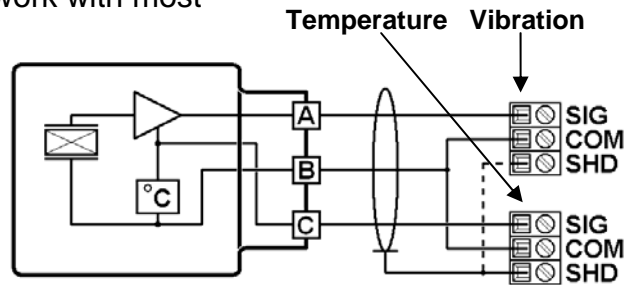

The shield must be wired to at least one shield connection point, but it is not necessary to connect it to both channel's shield connection. The temperature and the acceleration signals share the common connection. Illustrated here is a VL48EX switch box that will allow access to both signals for vibration and temperature sensors such as the 786T.

Each 12-channel board will be dedicated to either the vibration function or the temperature function. Since one switch board will be for temperature and one for vibration, the boards will usually be installed in pairs (VL24EX or VL48EX).

When the 786T is wired to a switch box, the temperature signal for the 786T will be energized when the accelerometer is powered. An illustrated example of the connection from an analyzer is shown. An adapter connects to the analyzer's 25-pin input connector. Two BNC-ended cables plug into the adapter and connect to two BNC connections in the switch box, one on each of the appropriate switch box boards. When the accelerometer circuit is powered by the analyzer, the temperature voltage signal will be available at the "voltage" connection of the adapter. The voltage developed at the input is shown in the table in the appendix of this guide. All readings are in degrees Celsius.

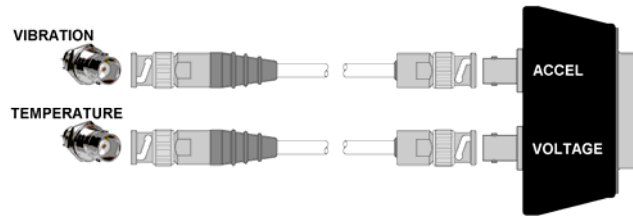

Some users may want to use a single 786T where there is only one point of interest to monitor. The Wilcoxon CB2 or CB4 junction box can be used to accomplish small monitoring tasks.

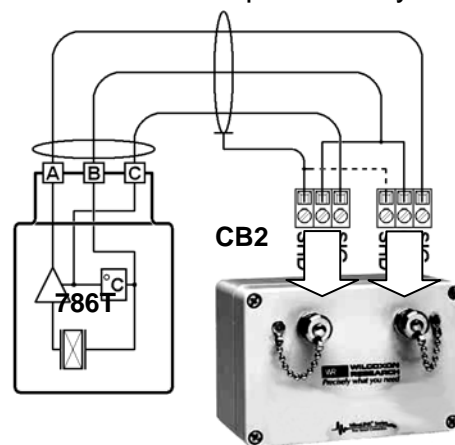

Wiring dual output accelerometers to an on-line vibration monitoring system

The 793T-3 and 797T-1 accelerometers incorporate a temperature sensor that requires separate powering. This is allowable because the connection and use of these models differ from the 786T. In most cases, the on-line system does not simultaneously measure temperature and vibration for a single location. Having the temperature sensor separately powered from the accelerometer makes operating the on-line systems easier. The system can schedule the temperature measurement without having to coordinate power to an accelerometer.

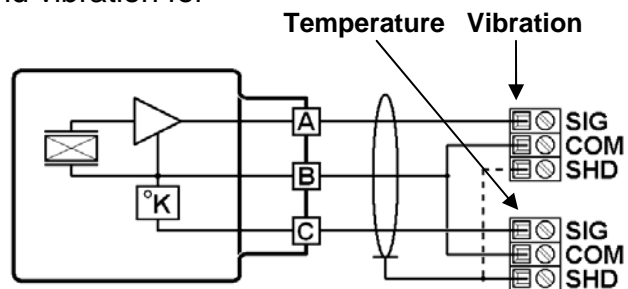

The shield (SHD) connection to an on-line system must connect to the system reference ground.

The accelerometer and temperature sensors are each wired to their own channel. The sensors share the same common connection so it must be split and wired to

each channel's common connection. When wiring the shield, it only needs one termination point. The voltages developed at the terminals of the sensor are shown in the table in the appendix of this guide. All readings are in degrees Kelvin.

Process system dual output sensor wiring

The PC425 and PC427 series of dual output sensors are designed to offer process system monitoring of temperature at the same location as the 4-20 mA vibration measurement.

Two sets of shielded, twisted pair wires should be used to connect to the PC425 or PC427 dual output sensor. The sensor uses the Wilcoxon J95 cable and is wired according to the table.

Designation	J95 Wire	PC425 pin
Loop +	Red	A
Loop -	Black	B
Temp. Signal	Yellow	D
Temp. Common	Green	E

Powering the temperature sensor of the PC425 or PC427 requires applying about 1 mA of current through the temperature sensor terminals. This can be accomplished by using a 22 kilohm resistor wired from the PLC/DCS +24 VDC supply to the voltage input of the PLC/DCS. The resistor will allow the proper current to flow to the sensor for operation. The voltages developed at the input are shown in the table in the appendix of this guide. All readings are in degrees Kelvin.

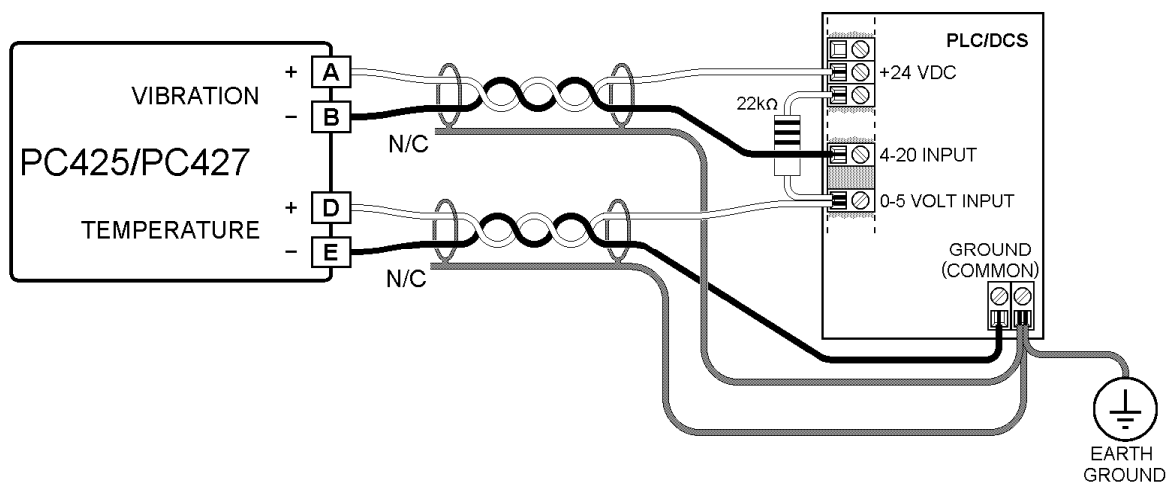



Appendix

Temperature-voltage tables for degrees Kelvin and degrees Celsius output

° Celsius	° Kelvin	° Fahrenheit	Celsius voltage ¹	Kelvin voltage
-40	233	-40	*	2.33 V
0	273	32	*	2.73 V
10	283	50	0.100 V	2.83 V
20	293	68	0.200 V	2.93 V
30	303	86	0.300 V	3.03 V
40	313	104	0.400 V	3.13 V
50	323	122	0.500 V	3.23 V
60	333	140	0.600 V	3.33 V
70	343	158	0.700 V	3.43 V
80	353	176	0.800 V	3.53 V
90	363	194	0.900 V	3.63 V
100	373	212	1.000 V	3.73 V
110	383	230	1.100 V	3.83 V
120	393	248	1.200 V	3.93 V

¹The lower limit of the Celsius temperature output is 2° C.