

4-20 mA monitoring of chillers and cooling units

Cooling towers, process coolers and HVAC cooling units can be monitored for vibration using the 4-20 mA analog input channels of existing PLC units.

Control system data input

Most modern chiller and cooler systems are operated by a process control system, such as a Programmable Logic Controller (PLC). PLCs have the ability to accept 4-20 mA analog input signals. Plants that utilize a PLC for operation often use this capability to achieve the cost savings of online vibration monitoring by sending 4-20 mA analog vibration data directly to their PLC.

Standard accelerometers output dynamic vibration data that is too complex to be input to a PLC. However, there are two methods to make a 4-20 mA vibration signal available to the PLC system. Traditional dynamic Integrated Electronic Piezoelectric (IEPE) accelerometers can be wired through a signal conditioning vibration transmitter module to create 4-20 mA output. Another option is accelerometers with the signal conditioner inside, which directly output the required 4-20 mA signal from the sensors, such as Wilcoxon's Loop Powered Sensors (LPS®).

Most accelerometers are suitable for hot and humid industrial environments, but can fail when exposed to high transient voltages. High voltage (HV) series accelerometers are immune to electrically noisy environments by providing extraordinary EMI and EFT protection and high electrical isolation between the sensor circuitry and the machine.

Monitoring fans running above 300 RPM

Small cooling cells and many HVAC cooling system fans will have fan speeds over 300 RPM. Where fan speeds exceed 300 RPM, the LPS® work well. Dynamic vibration data is converted to a 4-20 mA signal within the sensor housing and output directly to a PLC, with no need for additional monitoring units. Fan speeds above 300 RPM are best monitored with Wilcoxon models PC420VR-10 or PC420VP-10.

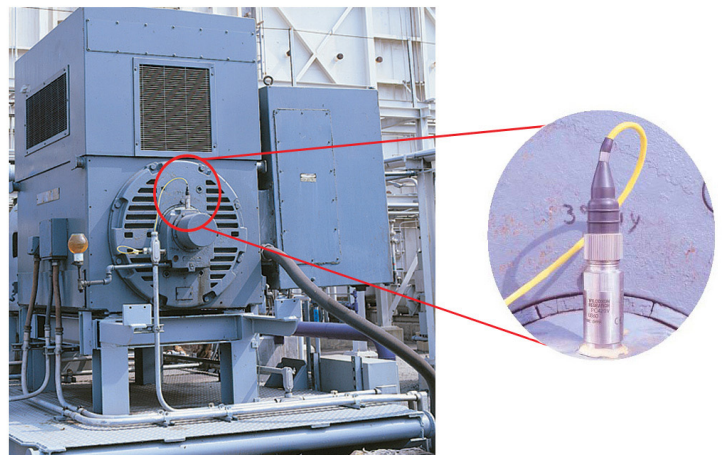

Monitoring fans running below 300 RPM

Large cells, towers and coolers will have slower speeds, typically below 300 RPM. At slower speeds, the vibration signal becomes very small. The small signals from slower rotating speeds require special consideration to accurately detect imbalance and looseness.

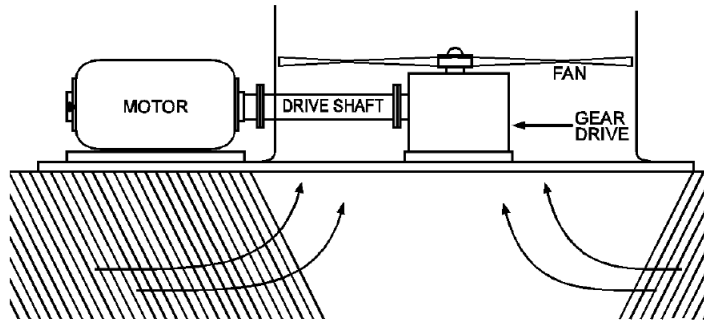

A typical large cell motor-fan

The Wilcoxon 799LF is an excellent low-frequency accelerometer to use for low-speed monitoring. The 799LF, however, is an IEPE accelerometer and does not produce a direct 4-20 mA signal. The Wilcoxon iT122 vibration transmitter, when used with the 799LF accelerometer, will produce a 4-20 mA signal for use by the process control system. In addition, the raw vibration data is still available for further vibration analysis. The combined 799LF and iT122 can monitor fans at speeds as slow as 60 RPM with accurate results.

Sensor locations

A primary concern in cooling units is the integrity of the fan assembly. A failure of the fan assembly usually results in serious damage to the structure and potential damage to nearby structures or injury of personnel in the area around the cooling unit.

Whether an LPS® or a 799LF plus iT122 is used, mount the sensor on the side of the gearbox, as shown in the picture. This will allow the sensor to monitor the fan assembly for the onset of imbalance, as well as detection of developing looseness in the gearbox or supporting structure.

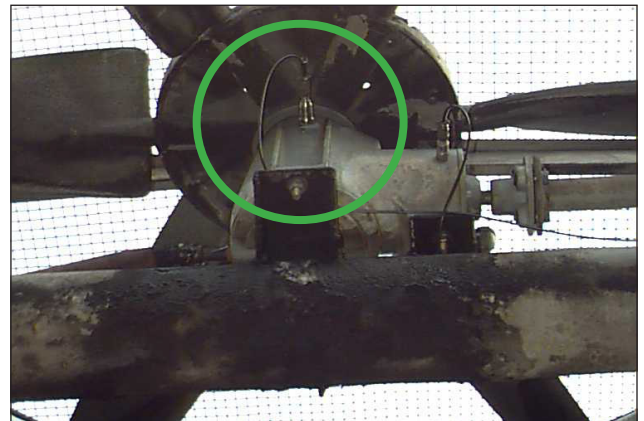

View of a large-cell fan from below, showing the mounting of a 799LF accelerometer on the side of the gearbox.

Connectors and cables

The wet or outdoor nature of chiller and cooling system installations requires that only the best cable and connectors should be used. The Wilcoxon 6Q boot connector has been tested for underwater installations and is the best connector to use for cooling towers, coolers, and HVAC system installations. The shield connection at the sensor will usually be isolated while the shield will connect at the PLC end of the cable.

The best cable to use is a Teflon® jacketed cable because of its superior chemical resistance. Wilcoxon's J9T2A cable has superior chemical and ultraviolet resistance, making it ideal for outdoor and wet environments.

Wiring overview

Illustrated below are the basic wiring connections for either type of sensor installation. Illustration 1 shows that the 799LF connects directly to the iT122 vibration transmitter. Illustrated here are the input, power, and output wiring connections. The 4-20 mA output of the iT122 unit will wire directly to the PLC system input. The J9T2A cable can be used for the connection from the 799LF to the iT122. Illustration 2 shows how the PC420VR-10 or PC420VP-10 is wired directly to the PLC system with the J9T2A cable.

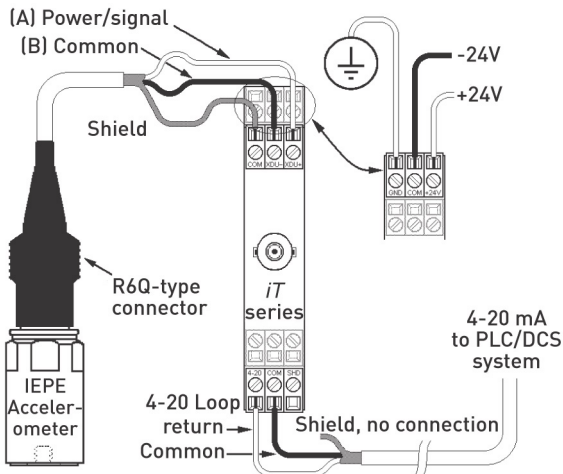

Illustration 1: The wiring connection from a 799LF to an iT122 or iT121

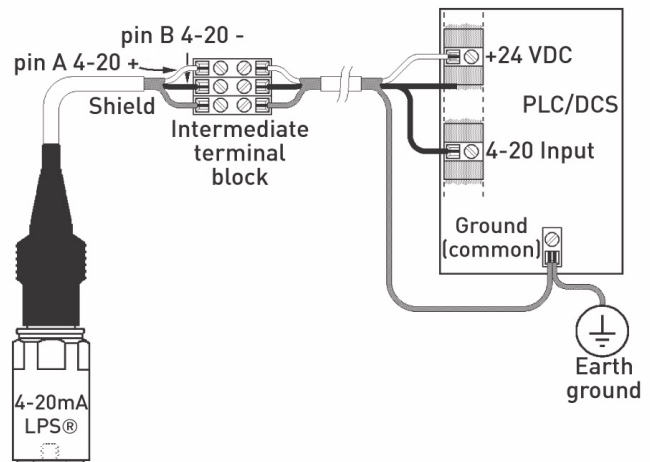

Illustration 2: The connection of a 4-20 mA LPS® to a PLC system

Summary

Cooling towers, process cooler and HVAC cooling units can be monitored for vibration using the 4-20 mA analog input channels of existing PLC units.

Fans running below 300 RPM are best monitored using a low-frequency accelerometer and a Wilcoxon iT Transmitter. This combination provides the best sensitivity and frequency response available on the market today for slow-speed machines.

Fan units running at speeds above 300 RPM can be monitored easily using the Wilcoxon's PC420VR-10 or PC420VP-10 LPS®.