

# Industrial vibration sensor selection: piezovelocity transducers

In many industrial monitoring applications, piezovelocity transducers have distinct advantages over piezoelectric accelerometers and traditional velocity pickups. Integration to velocity within the sensor overcomes low-frequency cable pickup and the input noise of data acquisition equipment. In addition, the inherent high-frequency attenuation of the velocity output greatly reduces overload distortion.

## Introduction to piezovelocity transducers

Today, a vast majority of machinery vibration information is recorded and quantified in terms of velocity. Most vibration measurements in the process industries are analyzed in terms of inches per second (ips) in the United States, or in mm/sec on the SI systems. Velocity readings are generally recommended for measurements in the 100 to 30,000 CPM (1.7 to 500 Hz) frequency band.

Accurate and reliable vibration sensors are critical for successful machinery monitoring programs. Piezovelocity transducers (PVTs) outperform general purpose accelerometers and electrodynamic velocity pickups on slow-speed equipment. In the 90 to 3,600 CPM range, PVTs' internal integration provides greater signal fidelity than standard accelerometers. Solid-state PVTs are more reliable and measure broader frequencies than electrodynamic pickups. For many permanent sensor installations in paper mills, steel, and power generation facilities, a PVT sensor is the best investment.

The PVT is essentially a piezoelectric accelerometer with an on-board velocity converter. The transducer employs a piezoceramic sensing element and dense seismic mass to produce a charge output proportional to acceleration. The high-impedance charge signal is converted within the sensor to a low-impedance voltage output and integrated to velocity. Section views of compression and shear mode PVTs are shown in figures 1a and 1b; the integration amplifier circuit diagram is shown in figure 2.

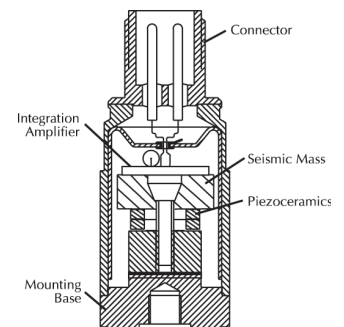

Figure 1a: Compression mode PVT

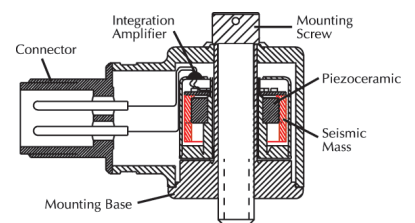

Figure 1b: Shear mode PVT

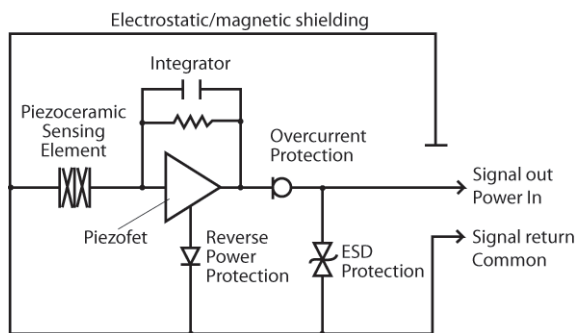

Figure 2: Circuit diagram for a PVT

## Limitations of electrodynamic pickups

In contrast to piezoelectric devices, electrodynamic pickups are used above the natural frequency of the transducer. Electrodynamic velocity pickups generate a very powerful output signal, but introduce phase errors at low frequency and are susceptible to electromagnetic fields. They also contain moving parts and are subject to wear or possible failure. Although modern designs minimize traditional deficiencies, solid-state piezoelectric devices are far more advanced.

The electrodynamic frequency response is very limited compared to PVTs. The typical 600 CPM (10 Hz) low-end cutoff frequency is above the running speed of many paper machines and other industrial equipment. Conversely, typical cutoff for PVTs is 90 CPM (1.5 Hz). Comparison response characteristics are given in figures 3a and 3b.

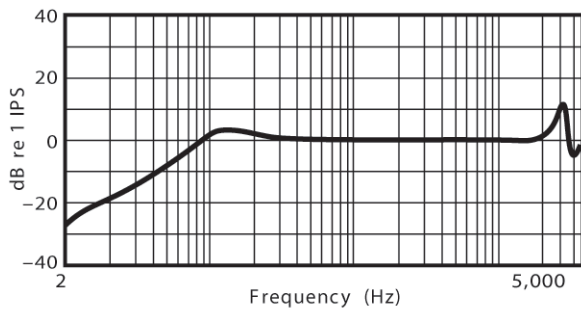

Figure 3a: Electrodynamic velocity pickup

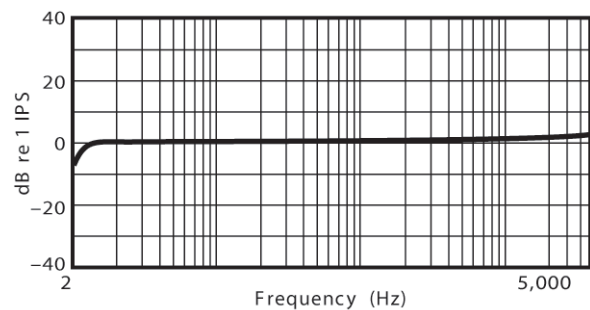

Figure 3b: PiezoveLOCITY transducer response

Many bearing and gear defects exhibit fault frequencies far above the range of electrodynamic pickups. High frequency usage of electrodynamic pickups is limited by the contact resonance of the mount. Depending on the sensor housing and mounting surface stiffness, the contact resonance varies between 120,000 and 180,000 CPM (2,000 to 3,000 Hz). The calibrated bandwidth is usually limited to 60,000 CPM (1,000 Hz). In contrast, piezoceramic PVTs measure well beyond 300,000 CPM (5,000 Hz).

## Piezoelectric accelerometers

Industrial accelerometers consist of a piezoceramic material sandwiched between a seismic mass and the structure base. The seismic mass and piezoceramic create a simple mass/spring system with a very high natural frequency. Accelerometers and PVTs use tungsten masses and lead-zirconate titanate piezoceramic to maximize sensitivity at low frequencies.

In the region below resonance, the mass applies a force to the piezoceramic material proportional to the vibratory acceleration of the structure. The piezoceramic, in response to the applied force, generates a proportional electric charge on its surface; the charge output is then available as a signal that is fed into the measurement circuit.

Accelerometers are extremely versatile and widely used for industrial machinery monitoring. Typical industrial accelerometers measure micro-g vibration levels from below 60 CPM to greater than 900,000 CPM (1 to 15,000 Hz). However, the PVT provides a stronger output on slow- to moderate-speed machinery.

In low-frequency applications, standard 100 mV/g accelerometers are limited by electronic amplifier and noise. Over the 90 to 3,600 CPM (1.5 to 60 Hz) frequency range, the PVT has a significantly greater signal-to-noise ratio than a

typical accelerometer. In most cases, PVTs can directly replace the piezoelectric accelerometer, even accepting the same mounting, connectors, cabling, powering and monitoring equipment.

Below 90 CPM, PVTs are limited by the cutoff frequency of the integration circuit. Relative to acceleration, the output of the PVT increases with decreasing frequency. The low-frequency cutoff is required to limit gain and keep the amplifier in its linear range. 500 mV/g low-frequency accelerometers are generally used on very slow-speed equipment.

### PVT low-frequency amplification

In many slow-speed applications, an accelerometer is externally integrated to velocity inside the data collecting monitor. Along with vibration information, the integration circuit amplifies low-frequency electronic noise from the sensor and the monitor. Figure 4 shows noise plots for a 100 mV/g general purpose accelerometer and a 100 mV/g PVT. The externally integrated electronic noise from the accelerometer is considerably higher than the PVT. This integration noise produces a response commonly referred to as “ski slope.”

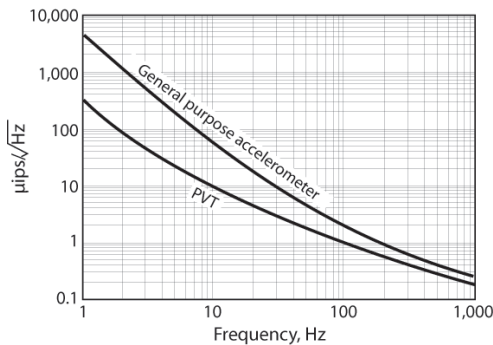

Figure 4: Noise response comparison between a 100 mV/g accelerometer and a 100 mV/g PVT, normalized in terms of velocity

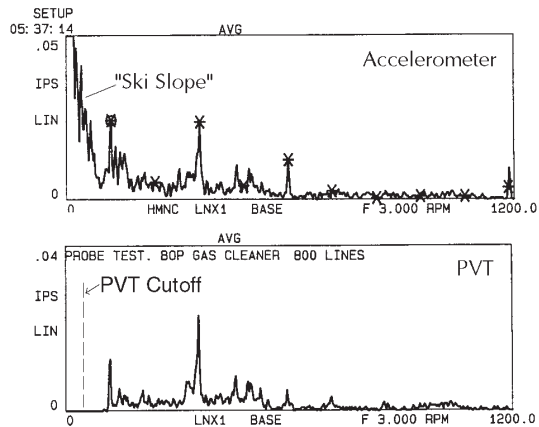

Figure 5: Spectral plot comparison of an accelerometer and a PVT

The spectral plots in figure 5, above, contrast the outputs of a PVT and an accelerometer. These readings, taken on a cooling tower fan, show “ski slope” integration noise affecting the accelerometer measurement. The fan running speed is 118.56 CPM.

### High-frequency mechanical noise attenuation

In some applications, very high amplitude signals are present far above the frequencies of interest. Accelerometers are inherently sensitive to high-frequency vibrations. Mechanical noise from machine structures can excite high frequencies and overload the internal amplifier. Amplifier overload will produce intermodulation distortion and severely interfere with low-frequency measurements. High-frequency noise sources include worn steam seals, air leaks, pump cavitation, and impacts from reciprocating machinery. Intermodulation distortion due to nondiscreet noise (e.g. steam “hiss”) is sometimes called washover distortion.

When an external integrator converts the acceleration signal to velocity, distortion products are amplified along with the low-frequency vibration data. These distortion products sometimes appear as a magnified “ski slope” and can

easily mask real vibration data. False signals can exceed alarm conditions and trigger shutdown of healthy machinery. Internal integration attenuates these signals before they can corrupt and obscure low-frequency data.

### **High-frequency electromagnetic noise**

High-frequency electromagnetic noise can also interfere with a low-frequency measurement. Accelerometer cables, installation routes, and termination enclosures may introduce false signals if they are not protected from electromagnetic radiation and transient sources. Electromagnetic noise sources include radio transmission, radar equipment, and electrostatic discharge.

Accelerometer amplifiers can operate as AM radio detectors, converting radio signals to audio frequencies. Cables, depending on length and location, will act as antennae and receive the radio transmissions. Once received, the amplifier can rectify the interference and insert low-frequency signals into the band of interest. The low-frequency amplification and high-frequency filtering of the PVT eliminate these problems.

### **PVT machinery health monitoring applications**

Measurement errors caused by low frequency distortion are particularly acute in industrial applications such as paper machine monitoring. In these applications, low amplitude, low-frequency signals are monitored in an environment surrounded by competing vibration sources and electromagnetic interference. PVTs are less susceptible to high-frequency sources, electrical or mechanical, and therefore eliminate many errors. In addition, velocity amplification inside of the sensor reduces the relative amplitude of any signals picked up by the cable before they enter the receiving system. Distortion products that may occur are small in comparison to the desired velocity signal.

### **Paper machine roller bearings**

PVTs have distinct advantages in paper machine applications where low-frequency noise reduction is a primary objective. Paper machine running speed faults are typically measured in the 100 to 1,200 CPM (1.7 to 20 Hz) band. PVTs prevent external integration noise from hiding looseness, misalignment and imbalance information. They also attenuate noise from steam seal leaks and electrostatic discharge.

In the bearing fault frequency bands below 120,000 CPM (2,000 Hz), PVTs compete with general purpose accelerometers and are far superior to electrodynamic pickups. Mount the PVT radially at the load zone of the bearing for greater sensitivity to high order fault harmonics.

PVTs are not recommended for use with HFD type measurements. Although the PVT will detect high-frequency impact noise, accelerometers will provide earlier warning of bearing faults. Very slow-speed rollers turning at speeds less than 100 CPM (1.7 Hz) should be monitored with 500 mV/g low-frequency accelerometers rather than with PVTs.

## Cooling towers

PVTs perform well in cooling tower applications. Many cooling tower fans operate in the 100 to 700 CPM (1.7 to 11.7 Hz) region. The PVT provides strong velocity data on fan speed, blade pass, looseness, and alignment. Mount the PVT horizontally on the pinion of the gearbox to increase sensitivity to gear mesh harmonics.

If fan speeds are less than 100 CPM (1.7 Hz), 500 mV/g low-frequency accelerometers should be used instead of PVTs. 100 mV/g accelerometers are generally used to monitor the motor end of the cooling tower.

## Vertical pumps

Vertical pumps typically operate between 300 and 1,800 CPM (5 to 30 Hz). PVTs provide earlier detection of imbalance and blade pass problems than standard accelerometers. The PVT eliminates mechanical overload from high-frequency cavitation noise.

If monitoring HFD for incipient bearing faults or cavitation problems, 100 mV/g accelerometers are preferable to PVTs. Use proximity probes to monitor relative movement of the pump shaft.

## Conclusions

Piezoelectric velocity sensors exhibit many advantages over traditional electrodynamic pickups and accelerometers for many industrial machinery applications. Particularly in low-frequency applications, PVTs provide more reliable data on vibration within the frequency range of interest, reducing integration noise and signal distortion from mechanical and electromagnetic interference.

PVTs are available in a variety of designs, including triaxial, handprobe and bolt through configurations. The sensitivity and frequency response can be factory-adjusted to customer specification. Amplifiers include such features as miswiring and electrostatic discharge protection circuitry. Intrinsically safe models with Factory Mutual, CSA and EECS certification are also available.

## References

- Guy, Kevin R. "Monitoring and Analysis with Electronic Data Collectors," Mini Course A, Mini Course Notes: 16th Vibration Institute National Meeting, 1992.
- Wowk, Victor. "Machinery Vibration: Measurements and Analysis," McGraw Hill Inc., 1991, pp. 66-69.
- Judd, John and Ramboz, John. "Special-Purpose Transducers," *Shock and Vibration Handbook*, 3rd ed., Cyril M. Harris, Ed., McGraw Hill Inc. 1988, pp. 14-1 to 14-5.
- Computational System Incorporated. "Selection of Proper Sensors for Low Frequency Vibration Measurements," *Noise & Vibration Control Worldwide*, October 1988, p. 256.
- Schloss, Fred. "Accelerometer Overload," *Sound and Vibration*, January 1989, p. 12.