

# Velocity loop powered sensors with dynamic vibration output

## PC420V-Dz dual output series

Wilcoxon's 4-20 mA vibration sensors integrate easily with an existing PLC, DCS or SCADA system. The PC420V-Dz series dual output sensors provide 24/7 monitoring of overall machine vibration for continuous trending, alerting users to changing machine conditions and helping to guide maintenance in prioritizing the need for service. The choice of true RMS or peak output allows you to choose the sensor that best fits your industrial requirements. The 4-20 mA output of the PC420A series is proportional to acceleration vibration. The dynamic output signal is derived from an internal buffered amplifier and requires that the 4-20 mA loop be powered.



**Table 1: PC420Vx-yy-Dz dual output model selection guide**

x (4-20 mA output type)	yy (4-20 mA full scale)	z (dynamic scale)
R = RMS output, velocity	05 = 0.5 ips	A = acceleration
P = equivalent peak output, velocity	10 = 1.0 ips	100 mV/g
	20 = 2.0 ips	V = velocity
	30 = 3.0 ips	100 mV/ips
	50 = 5.0 ips	

### Key features

- Choice of peak equivalent or true RMS output
- Dynamic signal output
- Easily integrated into existing process control systems
- Manufactured in an approved ISO 9001 facility

### Wiring diagram

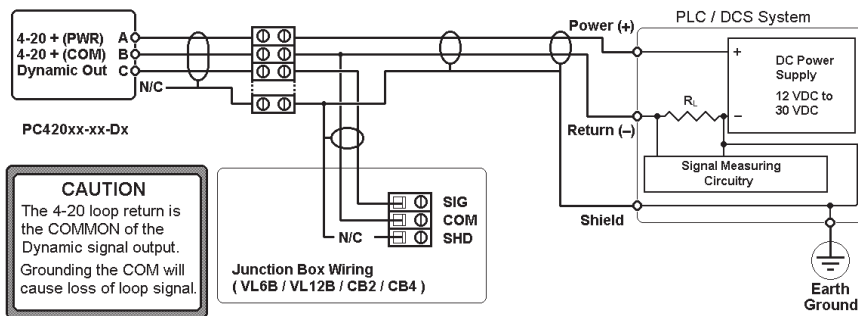

Note: Dynamic output must be galvanically isolated when connected to an on time system.

### Certifications



Note: Due to continuous process improvement, specifications are subject to change without notice. This document is cleared for public release.

# Velocity loop powered sensors with dynamic vibration output

## PC420V-Dz dual output series

### SPECIFICATIONS

<b>Output, 4-20 mA:</b>		
Full scale 20 mA, ±5%	see Table 1 on page 1	
Frequency response:	±10% ±3 dB	10 Hz - 1.0 kHz 4.0 Hz - 2.0 kHz
Repeatability	±2%	
Transverse sensitivity, max	5%	
<b>Dynamic output:</b>	<b>PC420V-DA</b>	<b>PC420V-DV</b>
Sensitivity, ±10%	100 mV/g	100 mV/in/sec
Full scale	20 g	1.5 ips at 1 kHz
Frequency response, ±3 dB	2.5 Hz - 10 kHz	2.5 Hz - 2.5 kHz
Amplitude nonlinearity, max	1%	
Resonant frequency, mounted, nominal	25 kHz	
Transverse sensitivity, max	5%	
<b>Power requirements (2-wire loop power):</b>		
Voltage at sensor terminal	12 - 30 VDC	
Loop resistance <sup>1</sup> at 24 VDC, max	700 Ω	
Turn on time, 4-20 mA loop	< 30 sec	
Dynamic output, bias output voltage	+3.3 VDC, re: connector pin B	
Dynamic output noise, equiv. g:	<b>PC420V-DA</b>	<b>PC420V-DV</b>
2.5 Hz - 10 kHz	2 mg	0.002 ips
<b>Grounding</b>	case isolated, internally shielded	
<b>Temperature range</b>	-40° to +85°C	
<b>Vibration limit</b>	250 g peak	
<b>Shock limit</b>	2,500 g peak	
<b>Sealing</b>	hermetic	
<b>Sensing element design</b>	PZT ceramic / shear	
<b>Weight</b>	162 grams	
<b>Case material</b>	316L stainless steel	
<b>Mounting</b>	1/4-28 tapped hole	
<b>Output connector</b>	3 pin, MIL-C-5015 style	
<b>Mating connector</b>	R6G type	
<b>Recommended cabling</b>	J9T3A	

Accessories supplied: SF6 mounting stud; calibration data (level 2)

Connections	
Function	Connector pin
loop positive (+)	A
loop negative (-), dynamic common	B
dynamic output	C
ground	shell

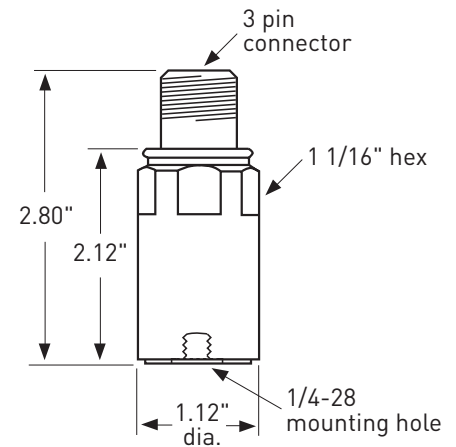

**Notes:** <sup>1</sup> Maximum loop resistance ( $R_L$ ) can be calculated by:

$$R_L = \frac{V_{DC\ power} - 10\ V}{20\ mA}$$

DC supply voltage	$R_L$ (max resistance) <sup>2</sup>	$R_L$ (minimum wattage capability) <sup>3</sup>
12 VDC	100 Ω	1/8 watt
20 VDC	500 Ω	1/4 watt
24 VDC	700 Ω	1/2 watt
26 VDC	800 Ω	1/2 watt
30 VDC	1,000 Ω	1/2 watt

<sup>2</sup> Lower resistance is allowed, greater than 10 Ω recommended.

<sup>3</sup> Minimum  $R_L$  wattage determined by:  $(0.0004 \times R_L)$ .

Note: Due to continuous process improvement, specifications are subject to change without notice. This document is cleared for public release.