

CG-L6 / CG-L8 Assembly Instructions

LOCATE AND IDENTIFY PARTS SHOWN BELOW. READ INSTRUCTIONS THOROUGHLY BEFORE STARTING ASSEMBLY

Packing List

Item	Description	PN	Qty
1	Cable Gland with Locknut, PG-36	A66013	1
2	Insert, 6 holes	65287-02	1 for CG-L6
	Insert, 8 holes	65287-04	1 for CG-L8
3	Gasket, Buna-N, PG-36	A14066	1
4	Plug	A22612	6 for CG-L6 8 for CG-L8

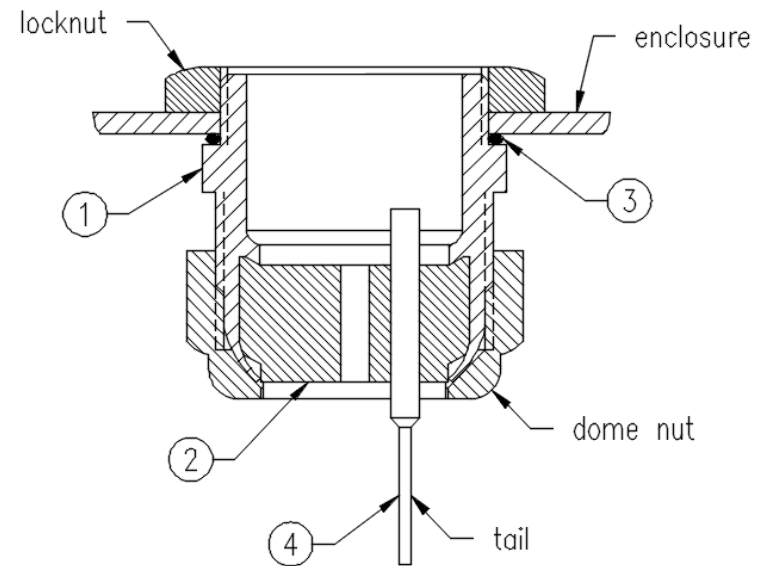

1. Drill Φ 1.850 +0.010/-0.005 inches hole in the enclosure.
2. Remove dome nut of Cable Gland (item 1) body; Remove existing seal insert and discard; Install supplied Insert (item 2) in place and reattach the dome nut. Hand tighten ONLY, at this time.
3. Remove Locknut from Cable Gland (item 1) body. Install Gasket (item 3) onto Cable Gland (item 1) body.
4. Install Cable Gland into predrilled enclosure hole and secure in place using Locknut.
5. Torque Locknut to ~ 66 in lb.
6. Loosen Cable Gland dome nut (no not remove) and feed cable(s) through hole(s) of Insert (item 2).
7. Install Plugs (item 4) into any unused Insert holes. Feed Plug from inside the enclosure, making sure the 'tail' is pulled completely through the Insert hole. 'Tail' should be left ON to facilitate the Plug removal in the future, should additional cables need to be connected to the enclosure.
8. Torque dome nut to ~ 44 in lb to seal cable(s) and, if applicable, plugs.