

Radiation resistant velocity transducer

793VR

SPECIFICATIONS

Sensitivity, $\pm 10\%$, 25°C		100 mV/in/sec
Velocity range		50 in/sec peak
Amplitude nonlinearity		2.5%
Frequency response:	$\pm 10\%$	2.5 - 3,500 Hz
	± 3 dB	2.0 - 7,000 Hz
Resonance frequency, mounted, nominal		15 kHz
Transverse sensitivity, max		5% of axial
Temperature response:	-50°C	-5%
	+120°C	+5%
Power requirement:		
Voltage source		18 - 30 VDC
Current regulating diode ¹		2 - 10 mA
Electrical noise, equiv. g, nominal:		
Broadband	2.5 Hz to 25 kHz	100 μ in/sec
Spectral	10 Hz	10 μ in/sec/ $\sqrt{\text{Hz}}$
	100 Hz	1.0 μ in/sec/ $\sqrt{\text{Hz}}$
	1,000 Hz	0.2 μ in/sec/ $\sqrt{\text{Hz}}$
Output impedance, nominal 4 mA supply		the greater of 5,000/f or 200 Ω
Bias output voltage, nominal		10 VDC
Grounding		case isolated, internally shielded
Temperature range		-50° to +120°C
Vibration limit		250 g peak
Shock limit		5,000 g peak
Electromagnetic sensitivity, equiv. in/sec		25 μ in/sec/gauss
Sealing		hermetic
Base strain sensitivity		0.0005 in/sec/ μ strain
Radiation exposure limit		1 x 10 ⁷ RADs
Weight		133 grams
Case material		stainless steel
Mounting		1/4-28 tapped hole
Output connector		2 pin, MIL-C-5015 style
Mating connector		R6, R6QN
Recommended cabling		J9T2

Notes: ¹ A maximum current of 6 mA is recommended for operating temperatures in excess of 100°C.
Accessories supplied: SF6 mounting stud; calibration data



Key features

- Radiation rated
- Manufactured in ISO 9001 facility

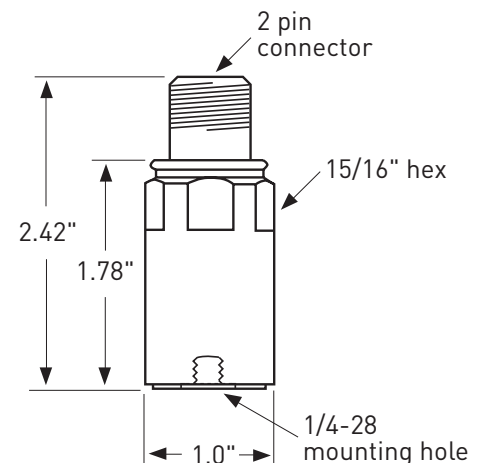

Note: Due to continuous process improvement, specifications are subject to change without notice.
This document is cleared for public release.

Connections	
Function	Connector pin
power/signal	A
common	B