

Electromagnetic/piezoelectric shaker system

F4/F7

SPECIFICATIONS

F4 electromagnetic shaker:

Usable frequency range	10 - 7,500 Hz
Blocked force output ¹	see graph on page 2
Maximum continuous current	1.5 amp rms
Maximum continuous current w/ air cooling	2.5 amps
Nominal electrical impedance	25 Ω
DC electrical resistance	13 Ω
Resonance frequency, blocked	40 Hz, nominal
Connector ²	Bendix PT06A-8-3S
Cable	R4M-8C-8C-J9B-10

F7 piezoelectric shaker/impedance head:

Usable frequency range	500 - 20,000 Hz
Blocked force output ¹	see graph on page 2
Maximum input, voltage	800 V rms
Maximum acceleration	1,000 g
Capacitance	8.0 nF
Connector ²	Bendix PT06A-8-3P
Cable	R4-4M-J9-10

Accelerometer nominal values:

Charge sensitivity	9 pC/g (0.92 pC/m/s ²)
Voltage sensitivity ³	13 mV/g
Capacitance ³	700 pF
Frequency range, ±3 dB	10 - 20,000 Hz
Connector ²	Microdot 10-32
Output cable	R1-1-J1-6

Force gage nominal values:

Charge sensitivity	175 pC/lb (39 pC/N)
Voltage sensitivity ³	75 mV/lb (17 mV/N)
Capacitance ³	2,300 pF
Frequency range, ±3 dB	10 - 40,000 Hz
Connector ²	Microdot 10-32
Output cable	R1-1-J1-6

Mass below force gage (including stud)	20 grams (0.044 lb)
Effective stiffness	3x10 ⁶ lb/in (5.2x10 ⁸ N/m)
Diameter of mounting surface	0.63 in. (1.66 cm)
Mounting stud, stainless steel	3/8-16 UNC
Recommended screw down torque	100 lb/in (11 N/m)
Temperature range	0° to +80°C
Base material	titanium

Weight:

Parts rigidly attached to structure (incl. F7)	3.4 lb (1.5 kg)
Suspended weight	4.8 lb (2.2 kg)
Total weight	8.2 lb (3.7 kg)



Key features

- Dual shaker combines high-frequency piezoelectric (F7) and low-frequency electromagnetic (F4) vibration generators to excite entire audio range
- Compact, attaches in any position with no external supports
- Built-in impedance head
- Manufactured in ISO 9001 facility

See reverse for dimensions, graphs and system diagram.

Notes: ¹ Blocked force output refers to the force output against a mass of infinite mechanical impedance.

² Refers to connector at shaker end of cable.

³ Refers to condition at the end of the 6 ft. low noise cable (180 pF).

Accessories supplied: All input and output cables; mounting stud; spanner wrench

Note: Due to continuous process improvement, specifications are subject to change without notice. This document is cleared for public release.

Electromagnetic/piezoelectric shaker system

F4/F7

Recommended system diagram

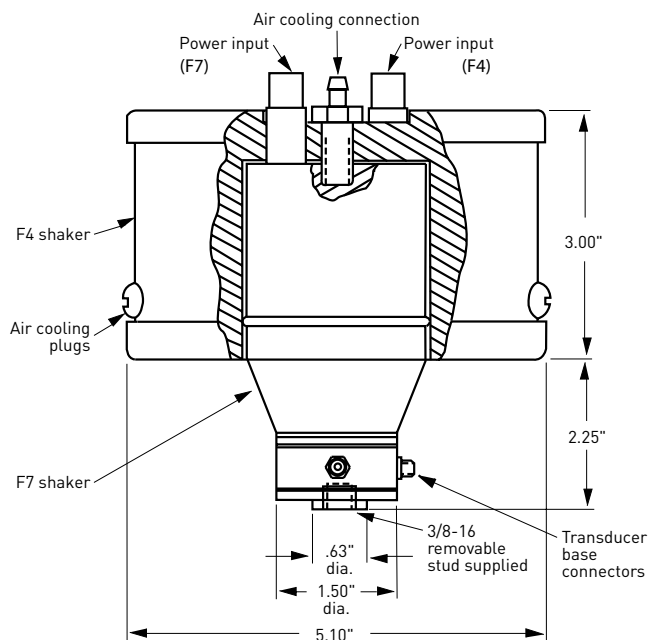
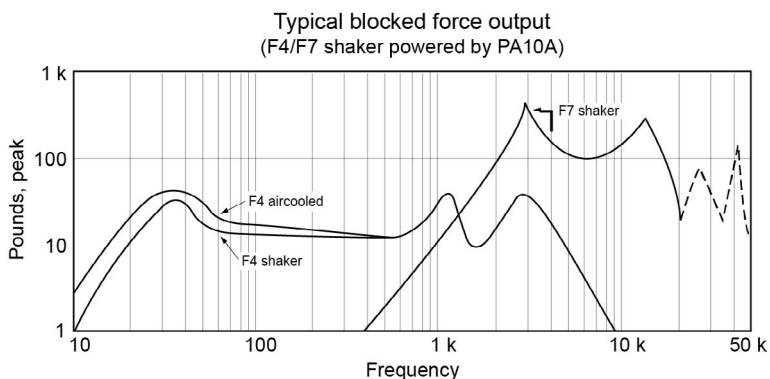
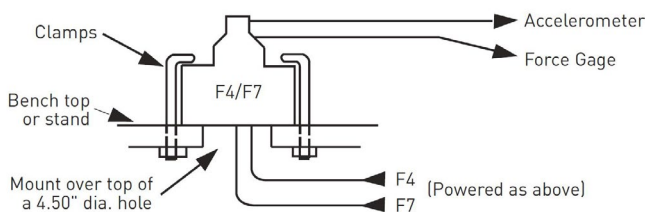
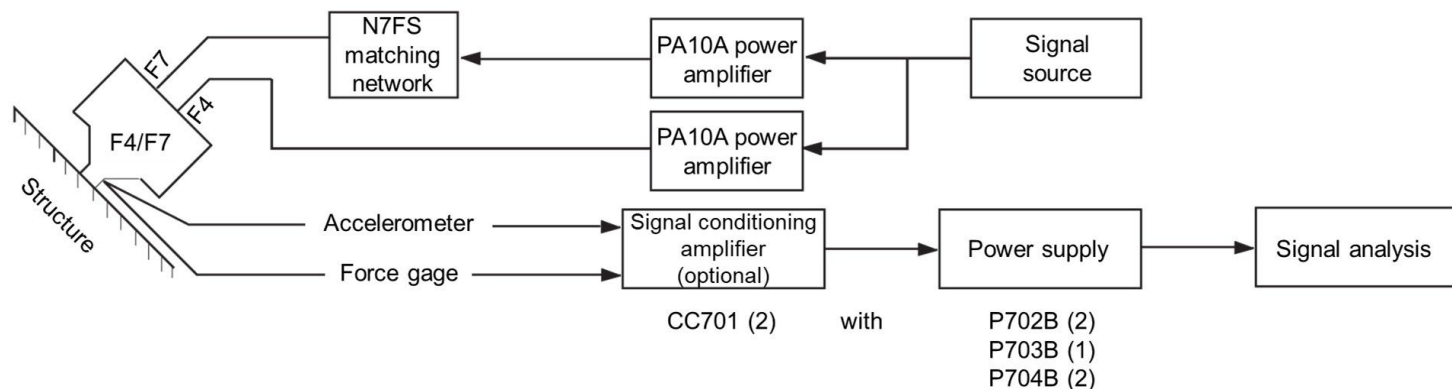

Note: Due to continuous process improvement, specifications are subject to change without notice. This document is cleared for public release.