

Intrinsically safe certified accelerometer





786A-IS

SPECIFICATIONS

Sensitivity, ±5%, 25°C		100 mV/g
Acceleration range		80 g peak
Amplitude nonlinearity		1%
Frequency response:	±5%	3 - 5,000 Hz
	±10%	1 - 9,000 Hz
	±3 dB	0.5 - 14,000 Hz
Resonance frequency		30 kHz
Transverse sensitivity, max		5% of axial
Temperature response:	-55°C	-20%
	+120°C	+10%
Power requirement:		
Voltage source		18 - 28 VDC
Current regulating diode		2 - 10 mA
Electrical noise, equiv. g:		
Broadband	2.5 Hz to 25 kHz	700 µg
Spectral	10 Hz	10 µg/√Hz
	100 Hz	5 µg/√Hz
	1,000 Hz	5 µg/√Hz
Output impedance, max		100 Ω
Bias output voltage		12 VDC
Grounding		case isolated, internally shielded
Temperature range		-55° to +120°C
Vibration limit		500 g peak
Shock limit		5,000 g peak
Electromagnetic sensitivity, equiv. g, max		70 µg/gauss
Sealing		hermetic
Base strain sensitivity, max		0.0002 g/µstrain
Sensing element design		PZT ceramic / shear
Weight		90 grams
Case material		316L stainless steel
Mounting		1/4-28 UNF tapped hole
Output connector		2 pin, MIL-C-5015 style
Mating connector		R6 type
Recommended cabling		J9T2B

Accessories supplied: SF6 mounting stud; calibration data (level 2)
Optional accessories available: ISBS-STD-08: MTL 7728 + safety barrier

CERTIFICATIONS

	Class I, Div 1 Groups A, B, C, D		II 1 G	
	Class II, Div 1 Groups E, F, G		Ex ia IIC T4 Ga	
	Class III		Ta = -50°C to 120°C	
	Class I Zone 0 AEx/Ex ia IIC T4			
	Ta = -50°C to 120°C			

Must be installed per document 12879. For application in explosive atmospheres caused by gases, vapours or mists and where the use of apparatus of category 1G is required, electrostatic charges on the cable and non-metallic parts of the enclosure shall be avoided. The ambient temperature range for these applications is -40°C to +80°C.



Key features

- Hazardous area certified - intrinsically safe
- MTBF 25 years
- API 670 compliant
- Manufactured in ISO 9001 facility

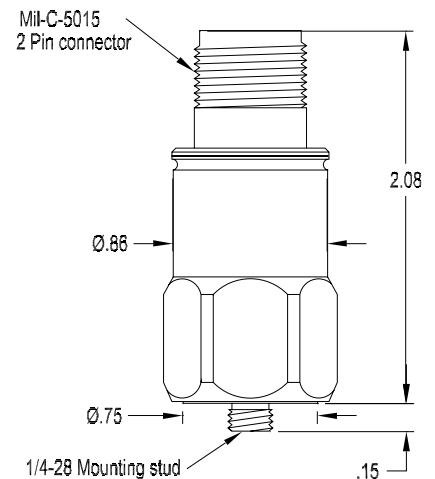

Connections	
Function	Connector pin
power/signal	A
common	B
ground	shell

Note: Due to continuous process improvement, specifications are subject to change without notice. This document is cleared for public release.