

Intrinsically Safe accelerometer with injection molded integral cable

786F-IM-IS

SPECIFICATIONS

Sensitivity, ±5%, 25°C	100 mV/g
Acceleration range	80 g peak
Amplitude nonlinearity	1%
Frequency response, nominal:	1 - 8,000 Hz
±10%	0.5 - 13,000 Hz
±3 dB	
Resonance frequency	30 kHz
Transverse sensitivity, max	5% of axial
Temperature response:	-5%
-50°C	+5%
+120°C	
Power requirement:	
Voltage source	18 - 30 VDC
Current regulating diode	2 - 10 mA
Electrical noise, equiv. g:	
Broadband	2.5 Hz to 25 kHz
Spectral	10 Hz
	100 Hz
	1,000 Hz
	700 µg
	10 µg/√Hz
	5 µg/√Hz
	5 µg/√Hz
Output impedance, max	100 Ω
Bias output voltage	12 VDC
Grounding	case isolated, internally shielded
Temperature range	-50° to +120°C
Vibration limit	500 g peak
Shock limit, min	5,000 g peak
Electromagnetic sensitivity, equiv. g, max	70 µg/gauss
Sensor sealing	hermetic
Integral cable sealing	IP68
Base strain sensitivity, max	0.0002 g/µstrain
Sensing element design	PZT ceramic / shear
Weight	90 grams (excluding cable)
Case material	316L stainless steel
Mounting	1/4-28 UNF tapped hole
Integral cabling	J9T2A, twisted, shielded pair, yellow Teflon jacket, 200°C, 16ft standard, blunt cut
Accessories supplied: SF6 mounting stud; calibration data (level 2)	



Key features

- Affordable injection molded integral cable
- Hermetically sealed sensor, IP68 molded cable
- Certified for use in Class I Div 1 and Zone 0/1 hazardous locations

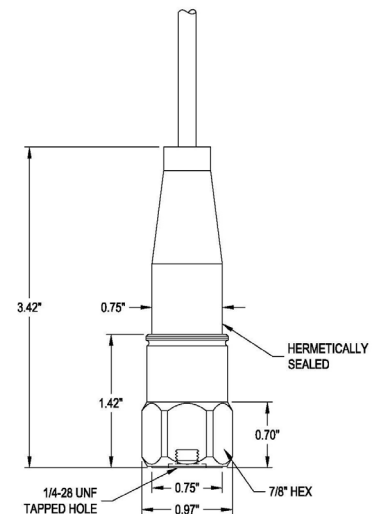

Certifications

	Class I, Div 1 Groups A, B, C, D		II 1 G	
	Class II, Div 1 Groups E, F, G		Ex ia IIC T4 Ga	
	Class III		Ta = -50°C to 120°C	
	Class I Zone 0 AEx/Ex ia IIC T4			
	Ta = -50°C to 120°C			

Must be installed per document 12879. For application in explosive atmospheres caused by gases, vapours or mists and where the use of apparatus of category 1G is required, electrostatic charges on the cable and non-metallic parts of the enclosure shall be avoided. The ambient temperature range for these applications is -50°C to +120°C.

Connections	
Function	Cable conductor
power/signal	white
common	black
case	shield

Note: Due to continuous process improvement, specifications are subject to change without notice. This document is cleared for public release.