

Intrinsically Safe accelerometer with injection molded, side exit integral cable

787F-IM-IS

SPECIFICATIONS

Sensitivity, ±5%, 25°C		100 mV/g
Acceleration range		80 g peak
Amplitude nonlinearity		1%
Frequency response:	±10%	1 - 5,000 Hz
	±3 dB	0.5 - 10,000 Hz
Resonance frequency		22 kHz
Transverse sensitivity, max		5% of axial
Temperature response:	-50°C	-5%
	+120°C	+5%
Power requirement:	Voltage source	18 - 30 VDC
	Current regulating diode	2 - 10 mA
Electrical noise, equiv. g, nominal:		
Broadband	2.5 Hz to 25 kHz	700 µg
Spectral	10 Hz	10 µg/√Hz
	100 Hz	5 µg/√Hz
	1,000 Hz	5 µg/√Hz
Output impedance, max		100 Ω
Bias output voltage		12 VDC
Grounding		case grounded, internally shielded
Temperature range		-50° to +120°C
Vibration limit		500 g
Shock limit, min		5,000 g
Electromagnetic sensitivity, equiv. g, max		70 µg/gauss
Sensor sealing		hermetic
Integral cable sealing		IP68
Base strain sensitivity, max		0.002 g/µstrain
Sensing element design		PZT ceramic / shear
Weight		145 grams
Case material		316L stainless steel
Mounting		1/4-28 captive hex head screw w/ 0.046" diameter safety wire hole
Integral cabling		J9T2A, twisted, shielded pair, yellow Teflon jacket, 200°C, 16ft standard, blunt cut

Accessories supplied: #80165-01 captive hex head screw; calibration data (level 2)



Key features

- Affordable injection molded integral cable
- Hermetically sealed sensor, IP68 molded cable
- Certified for use in Class I Div 1 and Zone 0 hazardous locations

Certifications

	Class I, Div 1 Groups A, B, C, D
	Class II, Div 1 Groups E, F, G
	Class III
	Class I Zone 0 AEx/Ex ia IIC T4
	Ta = -50°C to 120°C
	II 1 G
	Ex ia IIC T4 Ga
	Ta = -50°C to 120°C

Must be installed per document 12879. For application in explosive atmospheres caused by gases, vapours or mists and where the use of apparatus of category 1G is required, electrostatic charges on the cable and non-metallic parts of the enclosure shall be avoided. The ambient temperature range for these applications is -50°C to +120°C.

Connections

Function	Cable conductor color
power/signal	white
common	black
case	shield

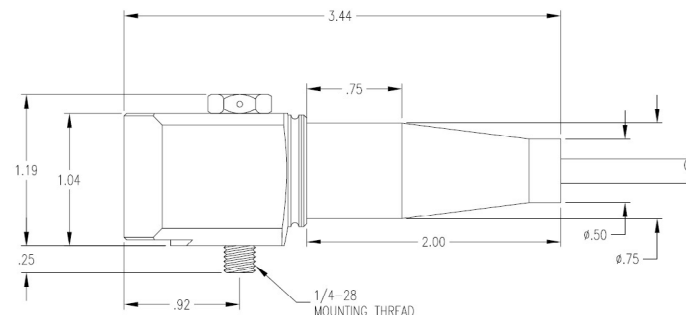

Note: Due to continuous process improvement, specifications are subject to change without notice. This document is cleared for public release.