

Injection molded, side exit, integral cable accelerometer

787F-IM

SPECIFICATIONS

Sensitivity, ±5%, 25°C		100 mV/g
Acceleration range		80 g peak
Amplitude nonlinearity		1%
Frequency response:	±10%	1 - 5,000 Hz
	±3 dB	0.5 - 10,000 Hz
Resonance frequency		22 kHz
Transverse sensitivity, max		5% of axial
Temperature response:	-55°C	-10%
	+120°C	+5%
Power requirement:	Voltage source	18 - 30 VDC
	Current regulating diode	2 - 10 mA
Electrical noise, equiv. g, nominal:		
Broadband	2.5 Hz to 25 kHz	700 µg
Spectral	10 Hz	10 µg/√Hz
	100 Hz	5 µg/√Hz
	1,000 Hz	5 µg/√Hz
Output impedance, max		100 Ω
Bias output voltage		12 VDC
Grounding		case isolated, internally shielded
Temperature range		-55° to +120°C
Vibration limit		500 g
Shock limit, min		5,000 g
Electromagnetic sensitivity, equiv. g, max		70 µg/gauss
Sensor sealing		hermetic
Integral cable sealing		IP68
Base strain sensitivity, max		0.002 g/µstrain
Sensing element design		PZT ceramic / shear
Weight		145 grams
Case material		316L stainless steel
Mounting		1/4-28 captive hex head screw w/ 0.046" diameter safety wire hole
Integral cabling		See Table 1

Accessories supplied: #80165-01 captive hex head screw; calibration data (level 2)



Key features

- Affordable injection molded integral cable
- Hermetically sealed sensor, IP68 molded cable
- API 670 compliant
- Manufactured in ISO 9001 facility

**TABLE 1: 787F-IM-X
CABLE SELECTION GUIDE**

-X (cable option)
-J9T2A = twisted, shielded pair, Yellow Teflon jacket, 200°C, 16ft standard, blunt cut
-J88LC = twisted, shielded pair, black polyurethane jacket, 80°C, 16ft standard, blunt cut

Connections	
Function	Cable conductor color
power/signal	white / red
common	black
N/C	shield

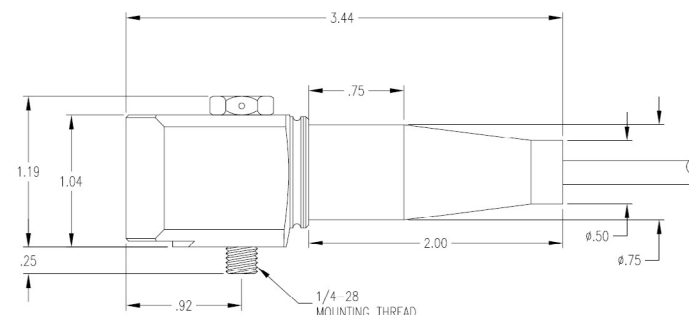

Note: Due to continuous process improvement, specifications are subject to change without notice. This document is cleared for public release.