

Ultra low power embedded accelerometer

LVEP050-TO5

SPECIFICATIONS

Sensitivity, $\pm 15\%$¹, 25°C		50 mV/g
Acceleration range		25 g peak
Amplitude nonlinearity		1%
Frequency response, nominal²:	$\pm 5\%$	3 - 5,000 Hz
	$\pm 10\%$	2 - 7,000 Hz
	± 3 dB	1 - 12,500 Hz
Resonance frequency, nominal		>25 kHz
Transverse sensitivity, max		7% of axial
Sensitivity variation with temp:	-25°C	+5%
	+120°C	-15%
Power requirement:		
Voltage source		3.0 - 5.5 VDC
Quiescent current, nominal		60 μ A
Power-down mode		0 μ A
Electrical noise, nominal, equiv. g:		
Broadband	2.5 Hz to 25 kHz	700 μ g
Spectral	10 Hz	35 μ g/ \sqrt Hz
	100 Hz	12 μ g/ \sqrt Hz
	1,000 Hz	6 μ g/ \sqrt Hz
Output impedance, max		1,000 Ω
Bias output voltage settling time³, nominal		350 μ s
Including temp effects		1.5 VDC $\pm 5\%$
Grounding	none: pellet case must be isolated from mounting surface	
Electromagnetic sensitivity, equiv. g, max	200 μ g/gauss	
Sensing element design	PZT, shear	
Sealing	hermetic	
Weight	3.2 grams	
Case material	304L stainless steel	
Header material	Kovar	
Mounting	epoxy; pellet case must be fully isolated from mounting surface and all other electrical connections	

Notes: ¹ Tighter sensitivity tolerance available upon request.

² Frequency response when epoxy mounted using flat shield surface.

³ Based on BOV within 10% of nominal BOV at 25°C. Power off for 30 sec minimum for fastest startup.



Key features

- 180 μ W power consumption
- Fast startup time, fast BOV settling time of 350 μ s
- Standardized TO-5 semiconductor package

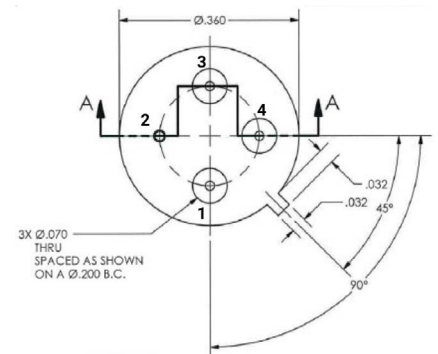
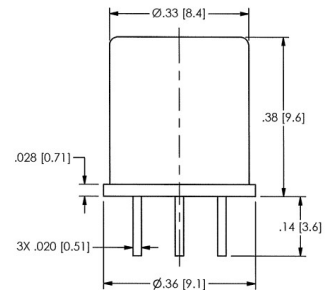

Connections	
Function	Pin
common	1
case	2 (keep isolated)
output	3
power	4

