

RMS and peak acceleration loop powered sensors

PCC420A series

Wilcoxon's PCC420A series sensors provide a 4-20 mA output proportional to vibration, allowing for continuous trending of overall machine vibration. This trend data alerts users to changing machine conditions and helps guide maintenance in prioritizing the need for service. The choice of RMS or peak output allows you to choose the sensor that best fits your requirements.



Table 1: PCC420Ax-yy-C model selection guide

x (4-20 mA output type)	yy (4-20 mA full scale)	C (output connector)
R = RMS output, acceleration P = calculated peak output, acceleration	05 = 5 g (49 m/sec ²) 10 = 10 g (98 m/sec ²) 20 = 20 g (196 m/sec ²) 50 = 50 g (490 m/sec ²)	R6 = 2 pin, MIL-C-5015 M12 = 4 pin, M12 F-IM-J9T2A = integral cable, twisted, shielded pair, Yellow Teflon jacket, 200°C, 16ft standard, blunt cut F-IM-J88LC = integral cable, twisted, shielded pair, black polyurethane jacket, 80°C, 16ft standard, blunt cut

Key features

- True RMS or calculated peak output
- Connector options: 2-pin MIL-C-5015, 4-pin M12, or integral cable
- Easily integrated into existing process control systems
- Compact housing for applications with height restrictions
- Manufactured in an approved ISO 9001 facility



Note: Due to continuous process improvement, specifications are subject to change without notice. This document is cleared for public release.

RMS and peak acceleration loop powered sensors

PCC420A series

SPECIFICATIONS

Full scale, 20 mA, ±5%		see Table 1 on page 1
Frequency response:	±10%	10 Hz - 1.0 kHz
	±3 dB	1.0 Hz - 2.0 kHz
Repeatability		±2%
Transverse sensitivity, max		5%
Power requirements, 2-wire loop power:		
Voltage at sensor terminals		12 - 30 VDC
Loop resistance ¹ at 24 VDC, max		700 Ω
Turn on time, 4-20 mA loop		< 30 seconds
Grounding		case isolated, internally shielded
Operating temperature range		-40° to +105° C
Vibration limit		250 g peak
Shock limit		2,500 g peak
Sensor sealing		hermetic
Integral cable sealing		IP68
Sensing element design		PZT, shear
Weight		120 grams
Case material		316L stainless steel
Mounting		1/4-28 UNF tapped hole
Output connection		see Table 1 on page 1
Mating connector:		
	-R6	2-socket MIL-C-5015 type
	-M12	4-socket M12
	-F	N/A
Recommended cabling:		
	-R6	J9T2A
	-M12	J9T2A
	-F	integral

Notes: ¹ Maximum loop resistance (R_L) can be calculated by: $R_L = \frac{V_{DC\ power} - 10\ V}{20\ mA}$

DC supply voltage	R_L (max resistance) ²	R_L (minimum wattage capability) ³
12 VDC	100 Ω	1/8 watt
20 VDC	500 Ω	1/4 watt
24 VDC	700 Ω	1/2 watt
26 VDC	800 Ω	1/2 watt
30 VDC	1,000 Ω	1/2 watt

² Lower resistance is allowed, greater than 10 Ω recommended.

³ Minimum R_L wattage determined by: $(0.0004 \times R_L)$.

Accessories supplied: SF6 mounting stud; calibration data (level 2)

Note: Due to continuous process improvement, specifications are subject to change without notice. This document is cleared for public release.

RMS and peak acceleration loop powered sensors

PCC420A series

DRAWINGS AND CONNECTIONS

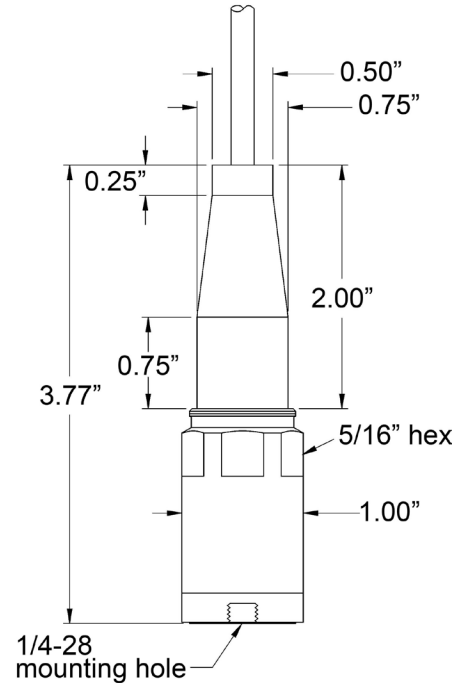
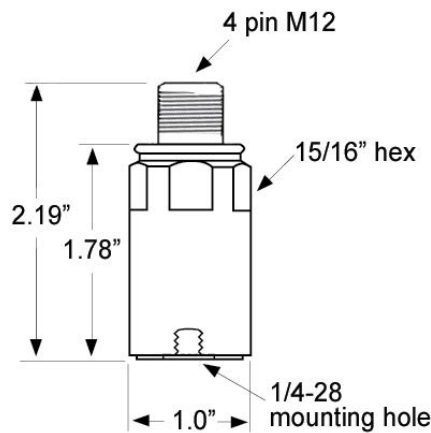
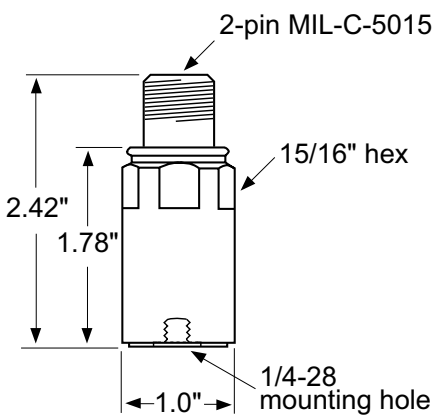

Connections (-R6 models)

Function	Connector pin
loop positive (+)	A
loop negative (-)	B
ground	shell

Connections (-M12 models)

Function	Connector pin
loop positive (+)	1
loop negative (-)	2
N/C	3
N/C	4
ground	shell

Connections (-F models)

Function	Cable color
loop positive (+)	white / red
loop negative (-)	black
N/C	shield

Typical circuit

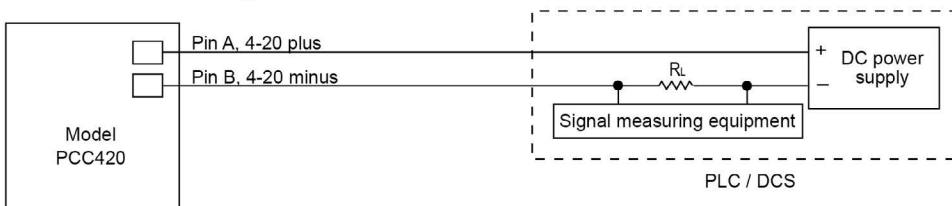

Note: Due to continuous process improvement, specifications are subject to change without notice. This document is cleared for public release.